

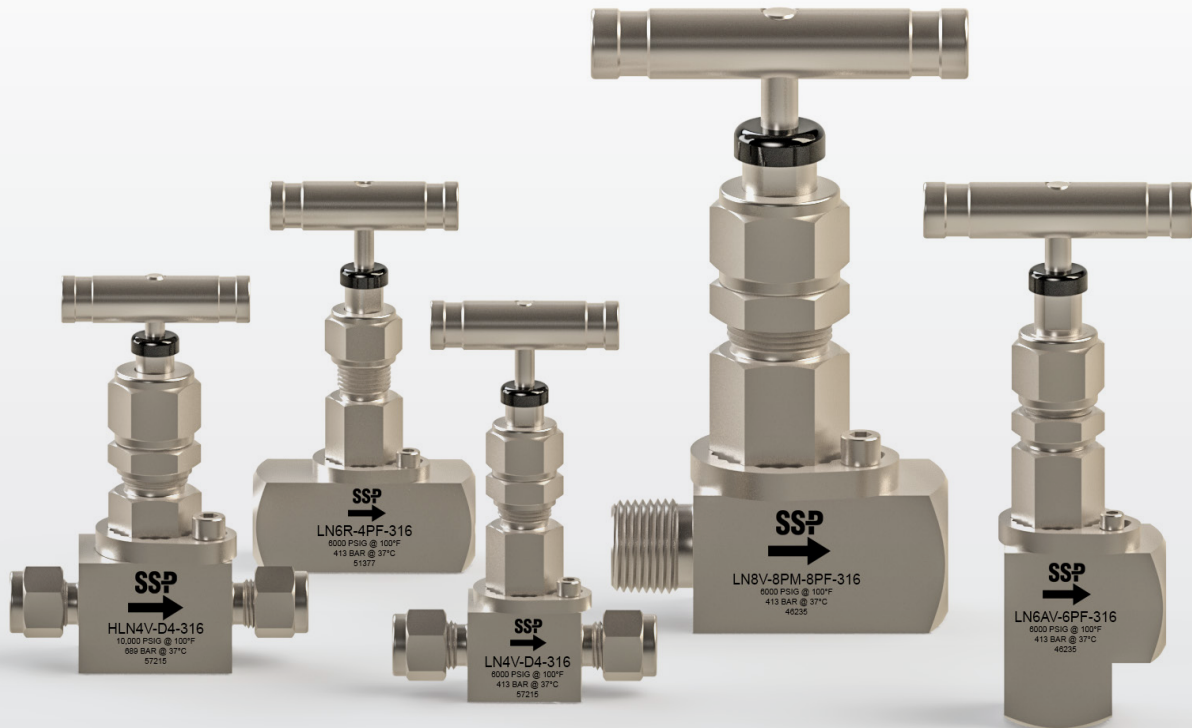

Locked Bonnet Needle Valves



LN & HLN Series

- ✓ Working Pressures up to 10,000 psig (689 bar)
- ✓ Temperature Range from -100 to 1200°F (-73 to 648°C)
- ✓ Flow Coefficients up to 2.18
- ✓ Locked bonnet eliminates loosening and accidental disassembly of the bonnet
- ✓ Non-rotating lower stem
- ✓ Live-loaded packing below the stem threads.



At SSP, we are proud to be an American manufacturing success story.

100% of our products are made in America. All of our manufacturing is performed in our 165,000 sq. ft. facility located near Cleveland, Ohio. Our facility is the largest vertically integrated, single-site operation in the industry. In addition to manufacturing and assembly, we have closed die forging, tool & die design, product engineering and testing operations under the same roof with customer service and management.

Made in America is good business. Not only do we make everything in America, we use American suppliers too. Buying American allows us to have better quality control and a more reliable supply chain. We can work more closely within our walls and with our suppliers to improve quality, reduce costs, and shorten lead times, which means faster service and better products for you.

Support where it counts. SSP products and services are supported by more than 4000 people and 350 distributor locations around the globe. For a distributor near you, contact SSP Customer Service or visit www.mySSP.com/distributors.

SSP Industry Standard Products.
Made Better.

TABLE of CONTENTS

Introduction	3	HLN High Pressure Needle Valves	9
Product Design	4	Options	10
Materials of Construction	5	Special Order Instructions	11
Temperature and Pressure Ratings	5	Testing, Safety, Warranty	11
Ordering Information	6		

LN Series Locked Bonnet Needle Valves

A Better Severe Service Needle Valve

LN Series and HLN Series Locked Bonnet Needle Valves offer important advantages over union bonnet and other severe service needle valve designs. LN Series valves are designed for severe service applications having pressures up to 6,000 psig (413 bar) and HLN Series valves are designed for working pressures up to 10,000 psig (689 bar). Both series can be used in applications with high vibration, corrosive media, and frequent cycling, in temperatures from -100 to 1200°F (-73 to 648°C).

Safer Bonnet Design

In the locked bonnet design, the bonnet is screwed into the valve body to create a metal to metal seal below the bonnet threads. The bonnet is locked in place with a lock ring, which is secured with a separate screw. This prevents accidental disassembly during packing adjustment, loosening due to vibration, or unscrewing of the bonnet by continuing to rotate the stem after the valve is fully open. The back-seating lower stem allows inline packing adjustments to be made more safely.

LN Series locked bonnet design

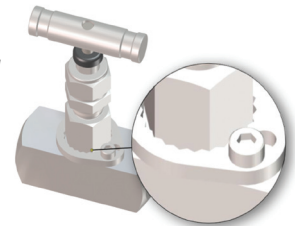

Better Non-Rotating Stem Tip Design

Unlike non-rotating ball stem tips, LN Series valves are designed with a non-rotating lower stem that prevents damage to the seat and stem tip and reduces wear to the packing. The threaded upper stem and stem pivot are located above the packing preventing system media from attacking the threads and washing away thread lubricants and to prevent contamination and corrosion from seizing up the non-rotating tip.

Stem pivot is protected above the packing.



Live-Loaded Chevron Packing below the threads and stem pivot.

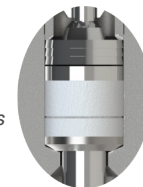

Lower stem does not rotate within the packing preventing seat and stem tip damage and reducing packing wear.

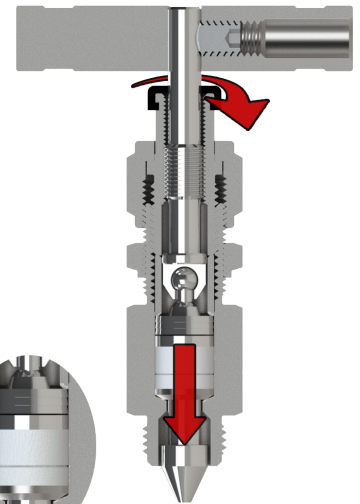

Leak-Tight Reliability and Low Maintenance

LN Series valves are designed with live-loaded packing that provides a dynamic leak-tight stem seal, which compensates for changes in pressure, temperature, and packing wear. Along with the non-rotating stem, live-loaded packing can reduce emissions, packing adjustments and maintenance.

Applications

LN Series valves provide reliable shut off, regulating and metering control in oil & gas exploration and refining, instrumentation, test stands, steam systems, control systems and many other applications where hazardous media, higher temperatures, pressures, and vibration are common.

LN Series Product Design

- 1 LIVE LOADED CHEVRON PACKING**

 - Reduces need for packing adjustments
 - Compensates for wear
 - Compensates for pressure and temperature changes
 - Packing support prevents extrusion of the packing
 - Flexible graphite packing is available for high-temperature applications
- 2 BACK SEATING STEM**

 - Easy access to packing bolt – nothing to disassemble
 - Allows in line packing adjustment in pressurized system
 - Isolates the packing when the valve is in the fully open position
 - Makes in-line packing adjustment safer
- 3 HARDENED NON-WETTED STEM THREADS**

 - Hardened 17-4 PH stainless steel
 - High cycle life
 - Retain lubricants for easy operation and longer cycle life
- 4 DUST CAP**

 - Prevents contamination of the stem threads from the environment
 - Colored vent and isolation caps for safety
- 5 BONNET LOCK PLATE**

 - Locks bonnet in place to prevent accidental disassembly
 - Positive lock is superior to pin-type retainers

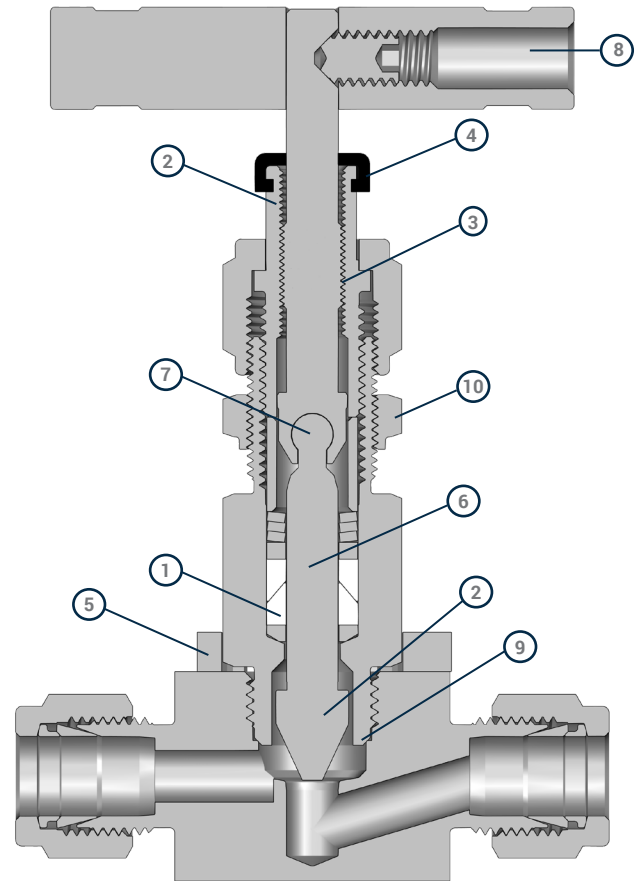

Meets ASME B31.1 and B31.3 design pressure calculations

- 6 NON ROTATING LOWER STEM**

 - Prevents damage to the seat and stem tip for repetitive leak-tight sealing even in severe environments
 - Reduces packing maintenance because the stem does not rotate within the packing
 - Vee-type, soft-seal shutoff, regulating, and metering stem tips are available
 - Chrome-plated, strain-hardened 316 SS
- 7 NON-WETTED, STEM PIVOT INTERLOCK**

 - Prevents system media from infiltrating and seizing up the stem joint
- 8 DURABLE STAINLESS STEEL HANDLE**

 - Large ergonomic handle for easier actuation
- 9 METAL TO METAL BONNET SEAL**

 - Higher temperatures and chemical compatibility

Materials of Construction

ID	Component	Body Material		
		316 SS	Alloy 400	Alloy C-276
1	Handle Screw	316 SS/A276		
2	T-Bar Handle	303/A582		
3	Cap	NBR/ D2000		
4	Packing Nut	316 SS/A276		
5	Packing Bolt	316 SS/A276		
7	Upper Stem	17-4 PH/ A564		
8	Packing Spacer	316 SS/A276		
9	Packing Springs	301/A666		
10	Packing Washer	316 SS/A276		
11*	Upper Packing	PTFE/D1710, Flexible Graphite, PEEK ¹		
12*	Lower Packing	PTFE/D1710, Flexible Graphite, PEEK ¹		
13*	Packing Support	316 SS/A276	Alloy 405/B164	Alloy C-276/B574
14*	Vee Stem	Chrome Plated 316 SS/A276	Chrome Plated Alloy 405/B164	Chrome Plated Alloy C-276/B574
15*	Metering Stem			
16*	Regulating Stem			
17*	Soft Seal Stem	316 SS/A276, PCTFE/AMS 3650	Alloy 405/B164, PCTFE/AMS 3650	Alloy C-276/B574 PCTFE/AMS 3650
18	Socket Screw	316 SS/A276		
19	Panel Nut	316 SS/A276		
20	Bonnet Lock	316 SS/A276		
21*	Bonnet	316 SS/A479	Alloy 405/ B164	Alloy C-276/B574
22*	Body	316 SS/A479	Alloy 400/B164	Alloy C-276/B574
	Packing Lubricant	Fluorocarbon-based lubricant		
	Thread Lubricant	Fluorocarbon-based lubricant with Tungsten Disulfide		

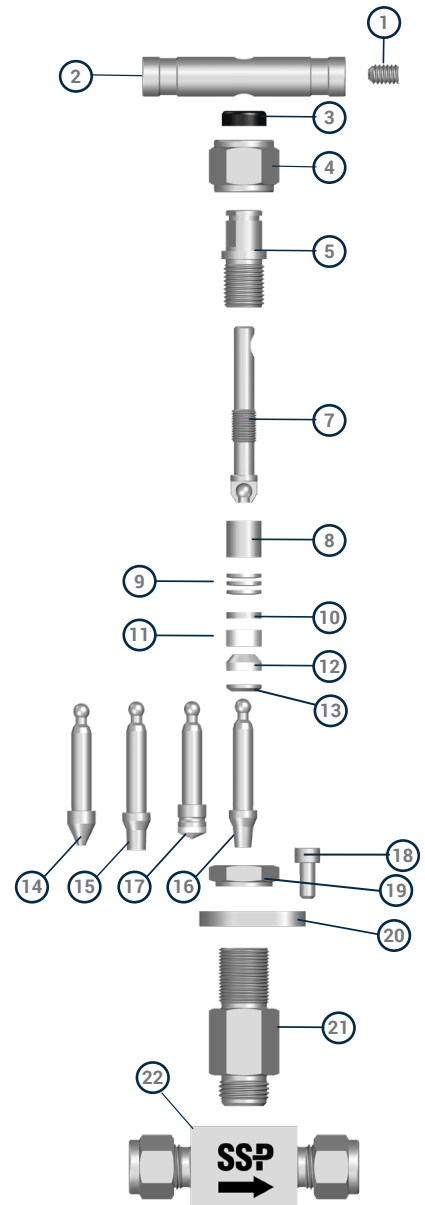

*Wetted components

¹PEEK Packing is available for LN6/HLN6 Series valves only.

Pressure - Temperature

Data reflects temperature ratings from both process and environmental sources. Pressure ratings are based on valves with graphite packing.

- 600°F (316°C) max. with PEEK* packing
- 450°F (232°C) max. with PTFE packing
- 200°F (93°C) max. with PCTFE stem tip

* Available for LN6 valves only.

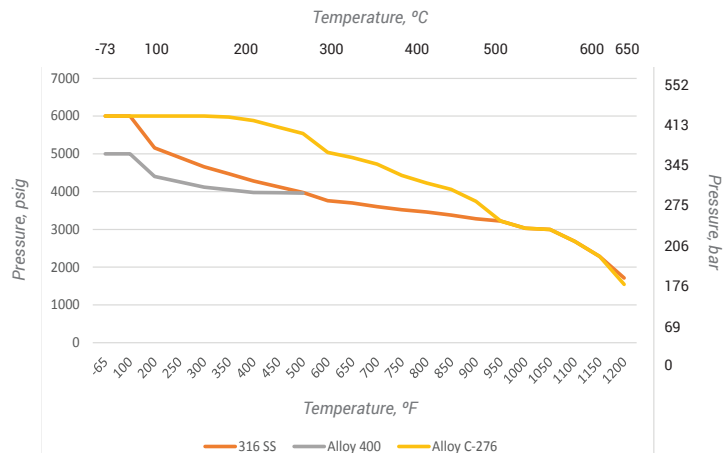

Flow Data

Valves with vee-tip and soft seal (PCTFE) tip stems are designed to be operated in the fully open or closed position. See the Part Number and Dimensions tables for flow data.

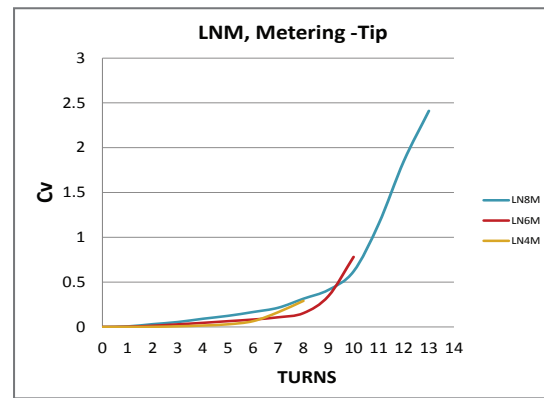
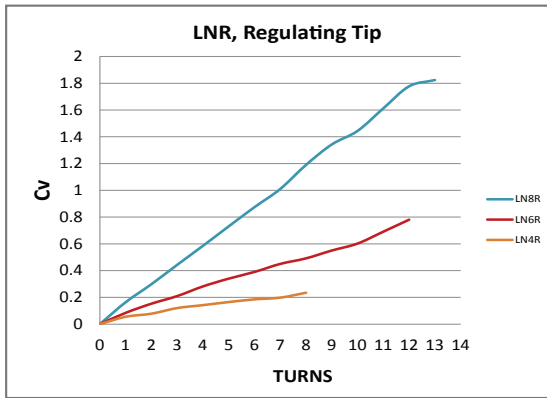

Ordering Information

To order LN Series valves, follow the steps below.

- 1 Locate the Basic Part Number & Dimensions table for the type of valve required.
LN Straight Pattern (page 06-07), LN Angle Pattern (page 08), HLN Straight Pattern (page 09)
 - 2 Locate the Basic Part Number with the required end connection type, end connection size and orifice size.
Example: **LN4A-D4**
Note: Duolok Tube Fitting end connections are standard. Unilok, and Griplik tube fitting end connections are also available. To order, please see Tube Fitting End Connections on page 10.
 - 3 Add the Stem Type Designator after the Valve Size Designator (see page 10). Example LN4AK-D4
 - 4 If optional flexible graphite or PEEK packing is required, add the Stem Packing Designator (See page 10).
Example: LN4AVG-D4
 - 5 Add the Body Material Designator. (See page 10) Example: LN4AK-D4-316
 - 6 Add designators for other options in alphabetical order. (See page 10) Example: LN4AK-D4-316-SG
- NOTE:** The Part Number and Dimensions Tables contain the most popular valve configurations. For other configurations, see the Special Order chart on page 11.

Basic Part Numbers and Dimensions

Straight Pattern Needle Valves

End Connection			Basic Part Number	Cv	Orifice in. (mm)	Dimensions ² , in. (mm)								
Type	Inlet Size	Outlet Size				A	B	D	E	F	G	H	J	K
Fractional Tube Fitting ¹	1/4 in.	1/4 in.	LN4-D4	0.34	0.156 (4.0)	2.40 (61.0)	1.20 (30.5)	1.09 (27.7)	0.41 (10.4)	1.75 (44.5)	9/16 (14.3)	3.22 (81.8)	7/64 (2.8)	0.24 (6.1)
	3/8 in.	3/8 in.	LN6-D6	0.84	0.250 (6.35)	2.83 (71.9)	1.42 (36.1)	1.34 (34.0)	0.50 (12.7)	2.50 (63.5)	11/16 (17.5)	3.93 (99.8)	5/32 (3.9)	0.28 (7.1)
	1/2 in.	1/2 in.	LN6-D8	0.85	0.250 (6.35)	3.04 (77.2)	1.52 (38.6)	1.34 (34.0)	0.50 (12.7)	2.50 (63.5)	11/16 (17.5)	3.93 (99.8)	5/32 (3.9)	0.28 (7.1)
	1/2 in.	1/2 in.	LN8-D8	1.90	0.437 (11.1)	3.92 (99.6)	1.96 (49.8)	1.82 (46.2)	0.63 (15.9)	3.50 (89.0)	1 1/32 (20.2)	5.03 (127.8)	3/16 (4.8)	0.32 (8.1)
	3/4 in.	3/4 in.	LN8-D12	2.18	0.437 (11.1)	3.92 (99.6)	1.96 (49.8)	1.82 (46.2)	0.63 (15.9)	3.50 (89.0)	1 1/32 (20.2)	5.03 (127.8)	3/16 (4.8)	0.32 (8.1)
	1 in.	1 in.	LN8-D16	2.18	0.437 (11.1)	4.29 (109.0)	2.15 (54.6)	1.88 (47.8)	0.69 (17.5)	3.50 (89.0)	1 1/32 (20.2)	5.16 (131.1)	3/16 (4.8)	0.32 (8.1)

¹Note: Unilok, and Griplik tube fitting end connections are also available. To order, please see Tube Fitting End Connections on page 10. Example: LN4A-U4

²Dimensions are for reference only and are subject to change.

Basic Part Numbers and Dimensions

Straight Pattern Needle Valves

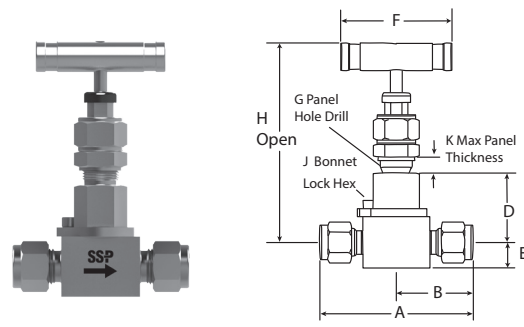

End Connection			Basic Part Number	Cv	Orifice in. (mm)	Dimensions ² , in. (mm)								
Type	Inlet Size	Outlet Size				A	B	D	E	F	G	H	J	K
Metric Tube Fitting	6 mm	6 mm	LN4-DM6	0.34	0.156 (4.0)	2.40 (61.0)	1.20 (30.5)	1.09 (27.7)	0.41 (10.4)	1.75 (44.5)	1 1/32 (20.2)	3.22 (81.8)	7/64 (2.8)	0.24 (6.1)
	8 mm	8 mm	LN4-DM8	0.34	0.156 (4.0)	2.54 (64.5)	1.27 (32.3)	1.09 (27.7)	0.41 (10.4)	1.75 (44.5)	9/16 (14.3)	3.22 (81.8)	7/64 (2.8)	0.24 (6.1)
	10 mm	10 mm	LN6-DM10	0.85	0.250 (6.35)	2.86 (72.6)	1.43 (36.3)	1.34 (34.0)	0.50 (12.7)	2.50 (63.5)	11/16 (17.5)	3.93 (99.8)	5/32 (3.9)	0.28 (7.1)
	12 mm	12 mm	LN6-DM12	0.85	0.250 (6.35)	3.04 (77.2)	1.52 (38.6)	1.34 (34.0)	0.50 (12.7)	2.50 (63.5)	11/16 (17.5)	3.93 (99.8)	5/32 (3.9)	0.28 (7.1)
	12 mm	12 mm	LN8-DM12	1.72	0.437 (11.10)	3.92 (99.6)	1.96 (49.8)	1.82 (46.2)	0.63 (15.9)	3.50 (89.0)	1 1/32 (20.2)	5.03 (127.8)	3/16 (4.8)	0.32 (8.1)
Female NPT	1/8 in.	1/8 in.	LN4-2PF	0.34	0.156 (4.0)	2.00 (50.8)	1.00 (25.4)	1.09 (27.7)	0.41 (10.4)	1.75 (44.5)	9/16 (14.3)	3.22 (81.8)	7/64 (2.8)	0.24 (6.1)
	1/4 in.	1/4 in.	LN4-4PF	0.34	0.156 (4.0)	2.06 (52.3)	1.03 (26.2)	1.09 (27.7)	0.41 (10.4)	1.75 (44.5)	9/16 (14.3)	3.22 (81.8)	7/64 (2.8)	0.24 (6.1)
	1/4 in.	1/4 in.	LN6-4PF	0.85	0.250 (6.35)	2.25 (57.2)	1.13 (28.70)	1.34 (34.0)	0.50 (12.7)	2.50 (63.5)	11/16 (17.5)	3.93 (99.8)	5/32 (3.9)	0.28 (7.1)
	3/8 in.	3/8 in.	LN6-6PF	0.85	0.250 (6.35)	2.25 (57.2)	1.13 (28.7)	1.34 (34.0)	0.50 (12.7)	2.50 (63.5)	11/16 (17.5)	3.93 (99.8)	5/32 (3.9)	0.28 (7.1)
	1/2 in.	1/2 in.	LN8-8PF	2.18	0.437 (11.1)	3.12 (79.3)	1.56 (39.6)	1.82 (46.2)	0.63 (15.9)	3.50 (89.0)	1 1/32 (20.2)	5.03 (127.8)	3/16 (4.8)	0.32 (8.1)
	3/4 in.	3/4 in.	LN8-12PF	2.18	0.437 (11.1)	3.25 (82.6)	1.63 (41.4)	1.91 (48.5)	0.78 (19.8)	3.50 (89.0)	1 1/32 (20.2)	5.34 (135.6)	3/16 (4.8)	0.32 (8.1)
	1 in.	1 in.	LN8-16PF	2.18	0.437 (11.1)	3.62 (92)	1.81 (46)	2.13 (54.1)	1.00 (25.4)	3.50 (88.9)	1 1/32 (20.2)	5.78 (146.8)	3/16 (4.8)	0.32 (8.1)
Male NPT	1/4 in.	1/4 in.	LN4-4PM	0.34	0.156 (4.0)	2.20 (55.9)	1.10 (27.9)	1.09 (27.7)	0.41 (10.4)	1.75 (44.5)	9/16 (14.3)	3.22 (81.8)	7/64 (2.8)	0.24 (6.1)
	1/2 in.	1/2 in.	LN8-8PM	2.00	0.437 (11.1)	3.50 (88.9)	1.75 (44.4)	1.82 (46.2)	0.63 (16.0)	3.50 (88.9)	1 1/32 (26.2)	5.03 (127.7)	3/16 (4.8)	0.32 (8.1)
Male to Female NPT	1/4 in.	1/4 in.	LN4-4PM-4PF	0.34	0.156 (4.0)	2.03 (51.6)	1.02 (25.9)	1.09 (27.7)	0.41 (10.4)	1.75 (44.5)	9/16 (14.3)	3.22 (81.8)	7/64 (2.8)	0.24 (6.1)
	1/2 in.	1/2 in.	LN8-8PM-8PF	2.00	0.437 (11.1)	3.12 (79.3)	1.56 (39.6)	1.82 (46.2)	0.63 (15.9)	3.50 (89.0)	1 1/32 (20.2)	5.03 (127.8)	3/16 (4.8)	0.32 (8.1)
	3/4 in.	3/4 in.	LN8-12PM-12PF	2.18	0.437 (11.1)	3.50 (89.0)	1.75 (44.5)	1.91 (48.5)	0.78 (19.8)	3.50 (89.0)	1 1/32 (20.2)	5.34 (135.6)	3/16 (4.8)	0.32 (8.1)
	1 in.	1 in.	LN8-16PM-16PF	2.18	0.437 (11.1)	3.75 (95.3)	1.88 (47.8)	2.13 (54.1)	1.00 (25.4)	3.50 (88.9)	1 1/32 (20.2)	5.78 (146.8)	3/16 (4.8)	0.32 (8.1)
Tube Socket Weld	1/4 in.	1/4 in.	LN4-4SW	0.34	0.156 (4.0)	1.85 (46.9)	0.93 (23.6)	1.09 (27.6)	0.41 (10.4)	1.75 (44.4)	9/16 (14.3)	3.22 (81.7)	7/64 (2.8)	0.24 (6.1)
	3/8 in.	3/8 in.	LN6-6SW	0.85	0.250 (6.35)	2.25 (57.1)	1.13 (28.7)	1.34 (34)	0.5 (12.7)	2.50 (63.5)	11/16 (17.5)	3.93 (99.8)	5/32 (3.9)	0.28 (7.1)
	1/2 in.	1/2 in.	LN6-8SW	0.86	0.250 (6.35)	3.15 (80)	1.58 (40.1)	1.82 (46.2)	0.63 (16)	3.50 (88.9)	11/16 (17.5)	5.03 (127.7)	5/32 (3.9)	0.32 (8.1)
	1/2 in.	1/2 in.	LN8-8SW	2.00	0.437 (11.1)	3.25 (82.5)	1.63 (41.4)	1.91 (48.5)	0.75 (19)	3.50 (88.9)	1 1/32 (20.2)	5.34 (135.6)	3/16 (4.8)	0.32 (8.1)
	3/4 in.	3/4 in.	LN8-12SW	2.00	0.437 (11.1)	3.12 (79.3)	1.56 (39.6)	1.82 (46.2)	0.63 (15.9)	3.50 (89.0)	1 1/32 (20.2)	5.03 (127.8)	3/16 (4.8)	0.32 (8.1)
Pipe Socket Weld	1/4 in.	1/4 in.	LN4-4PSW	0.34	0.156 (4.0)	1.82 (46.2)	0.91 (23.1)	1.09 (27.7)	0.41 (10.4)	1.75 (44.5)	9/16 (14.3)	3.22 (81.8)	7/64 (2.8)	0.24 (6.1)
	3/8 in.	3/8 in.	LN6-6PSW	0.85	0.250 (6.35)	2.40 (57.2)	1.20 (28.7)	1.34 (34.0)	0.50 (12.7)	2.50 (63.5)	11/16 (17.5)	3.93 (99.8)	5/32 (3.9)	0.28 (7.1)
	1/2 in.	1/2 in.	LN8-8PSW	2.00	0.437 (11.1)	3.12 (79.3)	1.56 (39.6)	1.82 (46.2)	0.63 (15.9)	3.50 (89.0)	1 1/32 (20.2)	5.03 (127.8)	3/16 (4.8)	0.32 (8.1)
	3/4 in.	3/4 in.	LN8-12PSW	2.00	0.437 (11.1)	3.12 (79.3)	1.56 (39.6)	1.82 (46.2)	0.63 (15.9)	3.50 (89.0)	1 1/32 (20.2)	5.03 (127.8)	3/16 (4.8)	0.32 (8.1)
Male SAE Straight	7/16-20	7/16-20	LN4-4MST	0.34	0.156 (4.0)	2.25 (57.1)	1.13 (28.7)	1.09 (27.6)	0.41 (10.4)	1.75 (44.4)	9/16 (14.3)	3.22 (81.7)	7/64 (2.8)	0.24 (6.1)
	9/16-18	9/16-18	LN6-6MST	0.85	0.250 (6.35)	2.25 (57.1)	1.13 (28.7)	1.34 (34)	0.50 (12.7)	2.50 (63.5)	11/16 (17.4)	3.93 (99.8)	5/32 (3.9)	0.28 (7.1)
	3/4-16	3/4-16	LN8-8MST	2.00	0.437 (11.1)	3.25 (82.5)	1.63 (41.4)	1.82 (46.2)	0.63 (16)	3.50 (88.9)	1 1/32 (26.2)	5.03 (127.7)	3/16 (4.8)	0.32 (8.1)
Female SAE Straight	7/16-20	7/16-20	LN4-4FST	0.34	0.156 (4.0)	2.00 (50.8)	1.00 (25.4)	1.09 (27.6)	0.41 (10.4)	1.75 (44.4)	9/16 (14.3)	3.22 (81.7)	7/64 (2.8)	0.32 (8.1)
	3/4-16	3/4-16	LN8-8FST	2.00	0.437 (11.1)	3.12 (79.2)	1.56 (39.6)	1.82 (46.2)	0.63 (16)	3.50 (88.9)	1 1/32 (26.2)	5.03 (127.7)	3/16 (4.8)	0.32 (8.1)

Basic Part Numbers and Dimensions

Angle Pattern Needle Valves

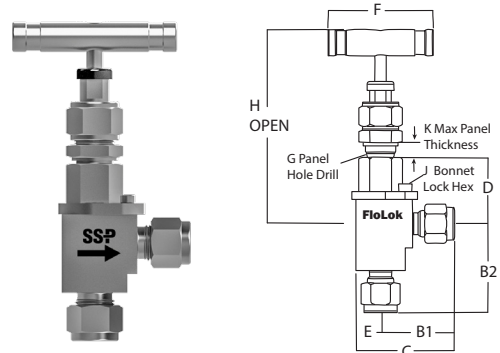

End Connection			Basic Part Number	Cv	Orifice in. (mm)	Dimensions ² in. (mm)									
Type	Inlet Size	Outlet Size				B1	B2	C	D	E	F	G	H	J	K
Fractional Tube Fitting ¹	1/4 in.	1/4 in.	LN4A-D4	0.34	0.156 (4.0)	1.16 (29.5)	1.48 (37.6)	1.57 (39.9)	1.09 (27.7)	0.41 (10.4)	1.75 (44.5)	9/16 (14.3)	3.22 (81.8)	7/64 (2.8)	0.24 (6.1)
	3/8 in.	3/8 in.	LN6A-D6	0.85	0.250 (6.35)	1.44 (36.6)	1.66 (42.2)	1.94 (49.3)	1.34 (34.0)	0.50 (12.7)	2.50 (63.5)	11/16 (17.4)	3.93 (99.8)	5/32 (3.9)	0.28 (7.1)
	1/2 in.	1/2 in.	LN6A-D8	0.85	0.250 (6.35)	1.55 (39.4)	1.65 (41.9)	2.05 (52.5)	1.34 (34.0)	0.50 (12.7)	2.50 (63.5)	11/16 (17.4)	3.93 (99.8)	5/32 (3.9)	0.28 (7.1)
	1/2 in.	1/2 in.	LN8A-D8	1.90	0.437 (11.1)	1.81 (46)	2.08 (52.8)	2.44 (62.0)	1.82 (46.2)	0.63 (15.9)	3.50 (89.0)	1 1/32 (20.2)	5.03 (127.8)	3/16 (4.8)	0.32 (8.1)
Metric Tube Fitting	6 mm	6 mm	LN4A-DM6	0.34	0.156 (4.0)	1.16 (29.5)	1.48 (37.6)	1.57 (39.9)	1.09 (27.7)	0.41 (10.4)	1.75 (44.5)	9/16 (14.3)	3.22 (81.8)	7/64 (2.8)	0.24 (6.1)
	8 mm	8 mm	LN4A-DM8	0.34	0.156 (4.0)	1.28 (32.5)	1.50 (38.1)	1.69 (42.9)	1.09 (27.7)	0.41 (10.4)	1.75 (44.5)	9/16 (14.3)	3.22 (81.8)	7/64 (2.8)	0.24 (6.1)
	10 mm	10 mm	LN6A-DM10	0.85	0.250 (6.35)	1.46 (37)	1.55 (39.4)	1.96 (49.8)	1.34 (34.0)	0.50 (12.7)	2.50 (63.5)	11/16 (17.4)	3.93 (99.8)	5/32 (3.9)	0.28 (7.1)
	12 mm	12 mm	LN6A-DM12	0.85	0.250 (6.35)	1.56 (39.6)	1.65 (41.9)	1.90 (48.3)	1.34 (34.0)	0.50 (12.7)	2.50 (63.5)	11/16 (17.4)	3.93 (99.8)	5/32 (3.9)	0.28 (7.1)
	12 mm	12 mm	LN8A-DM12	1.72	0.437 (11.1)	1.81 (46)	2.08 (52.8)	2.37 (60.2)	1.82 (46.2)	0.63 (15.9)	3.50 (89.0)	1 1/32 (20.2)	5.03 (127.8)	3/16 (4.8)	0.32 (8.1)
Female NPT	1/8 in.	1/8 in.	LN4A-2PF	0.34	0.156 (4.0)	0.89 (22.6)	1.00 (25.4)	1.30 (33.0)	1.09 (27.7)	0.41 (10.4)	1.75 (44.5)	9/16 (14.3)	3.22 (81.8)	7/64 (2.8)	0.24 (6.1)
	1/4 in.	1/4 in.	LN4A-4PF	0.34	0.156 (4.0)	0.89 (22.6)	1.00 (25.4)	1.30 (33.0)	1.09 (27.7)	0.41 (10.4)	1.75 (44.5)	9/16 (14.3)	3.22 (81.8)	7/64 (2.8)	0.24 (6.1)
	1/4 in.	1/4 in.	LN6A-4PF	0.85	0.250 (6.35)	1.00 (25.4)	1.12 (28.5)	1.50 (38.1)	1.34 (34.0)	0.50 (12.7)	2.50 (63.5)	11/16 (17.4)	3.93 (99.8)	5/32 (3.9)	0.28 (7.1)
	3/8 in.	3/8 in.	LN6A-6PF	0.85	0.250 (6.35)	1.12 (28.5)	1.12 (28.5)	1.50 (38.1)	1.62 (41.1)	0.50 (12.7)	2.50 (63.5)	11/16 (17.4)	3.93 (99.8)	5/32 (3.9)	0.28 (7.1)
	1/2 in.	1/2 in.	LN8A-8PF	2.18	0.437 (11.1)	1.56 (39.6)	1.56 (39.6)	2.00 (50.8)	2.19 (55.6)	0.63 (15.9)	3.50 (89.0)	1 1/32 (20.2)	5.03 (127.8)	3/16 (4.8)	0.32 (8.1)
Male NPT	1/4 in.	1/4 in.	LN4A-4PM	0.34	0.156 (4.0)	1.00 (25.4)	1.00 (25.4)	1.41 (35.8)	1.09 (27.7)	0.41 (10.4)	1.75 (44.5)	9/16 (14.3)	3.22 (81.8)	7/64 (2.8)	0.24 (6.1)
Male to Female NPT	1/4 in.	1/4 in.	LN4A-4PM-4PF	0.34	0.156 (4.0)	0.89 (22.6)	1.00 (25.4)	1.30 (33.0)	1.09 (27.7)	0.41 (10.4)	1.75 (44.5)	9/16 (14.3)	3.22 (81.8)	7/64 (2.8)	0.15 (3.8)
	1/2 in.	1/2 in.	LN8A-8PM-8PF	2.18	0.437 (11.1)	1.56 (39.6)	1.56 (39.6)	2.00 (50.8)	2.19 (55.6)	0.63 (15.9)	3.50 (89.0)	1 1/32 (20.2)	5.03 (127.8)	3/16 (4.8)	0.25 (6.4)
Tube Socket Weld	1/4 in.	1/4 in.	LN4A-4SW	0.34	0.156 (4.0)	0.88 (22.4)	1.19 (30.2)	1.29 (32.8)	1.09 (27.7)	0.41 (10.4)	1.75 (44.5)	9/16 (14.3)	3.22 (81.8)	7/64 (2.8)	0.24 (6.1)
	3/8 in.	3/8 in.	LN6A-6SW	0.86	0.250 (6.35)	1.00 (25.4)	1.25 (31.6)	1.50 (38.1)	1.34 (34.0)	0.50 (12.7)	2.50 (63.5)	11/16 (17.4)	3.93 (99.8)	5/32 (3.9)	0.28 (7.1)
	1/2 in.	1/2 in.	LN6A-8SW	0.85	0.437 (11.1)	1.00 (25.4)	1.25 (31.6)	1.50 (38.1)	1.34 (34.0)	0.50 (12.7)	2.50 (63.5)	11/16 (17.4)	3.93 (99.8)	5/32 (3.9)	0.28 (7.1)
	1/2 in.	1/2 in.	LN8A-8SW	2.00	0.437 (11.1)	1.56 (39.6)	1.69 (42.9)	2.00 (50.8)	2.19 (55.6)	0.63 (15.9)	3.50 (89.0)	1 1/32 (20.2)	5.03 (127.8)	3/16 (4.8)	0.32 (8.1)
Pipe Socket Weld	1/4 in.	1/4 in.	LN4A-4PSW	0.34	0.156 (4.0)	0.88 (33.4)	1.19 (30.2)	1.29 (32.8)	1.09 (27.7)	0.41 (10.4)	1.75 (44.5)	9/16 (14.3)	3.22 (81.7)	7/64 (2.8)	0.24 (6.1)
	3/8 in.	3/8 in.	LN6A-6PSW	0.85	0.250 (6.35)	1.20 (30.5)	1.25 (31.8)	1.70 (43.2)	1.34 (34.4)	0.50 (12.7)	2.50 (63.5)	11/16 (17.4)	3.93 (99.8)	5/32 (3.9)	0.28 (7.1)
	1/2 in.	1/2 in.	LN8A-8PSW	2.00	0.437 (11.1)	1.50 (38.1)	1.69 (42.9)	2.13 (54.1)	1.82 (19.0)	0.63 (88.9)	3.50 (89.0)	1 1/32 (20.2)	5.34 (135.6)	3/16 (4.8)	0.32 (8.1)

¹Note: Unilok, and Griplok tube fitting end connections are also available. To order, please see Tube Fitting End Connections on page 10. Example: LN4A-U4

²Dimensions are for reference only and are subject to change.

HLN Series High Pressure Needle Valves

HLN Series valves are designed for applications with working pressures up to 10,000 psig (689 bar) and temperatures from -100 to 1200° F (-73 to 648° C).



HLN Pressure-Temperature

Data reflect temperature ratings from both process and environmental sources. Pressure ratings are based on valves with 316 SS bodies and flexible graphite packing.

- 600°F (316°C) max. with PEEK* packing
- 450°F (232°C) max. with PTFE packing
- 200°F (93° C) max. with PCTFE stem tip

* Available for HLN6 valves only.

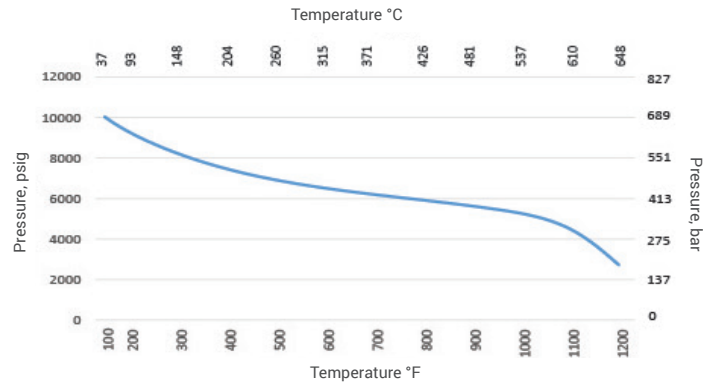

Basic Part Numbers and Dimensions

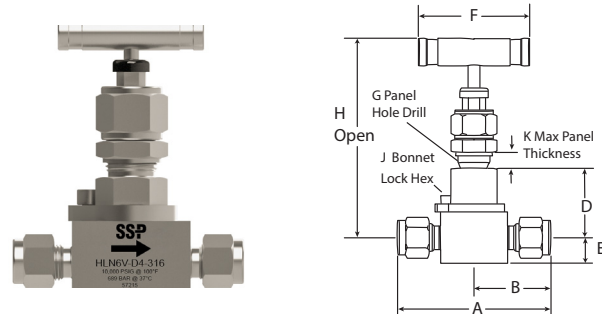

End Connection			Basic Part Number ¹	Cv	Orifice in. (mm)	Dimensions ² in. (mm)								
Type	Inlet Size	Outlet Size				A	B	D	E	F	G	H	J	K
Fractional Tube Fitting ¹	1/4 in.	1/4 in.	HLN4-D4	0.34	0.156 (4.0)	2.82 (71.6)	1.41 (35.8)	1.09 (27.7)	0.50 (12.7)	1.75 (44.5)	11/16	3.17 (80.5)	5/32 (3.9)	0.24 (6.1)
Female NPT	1/8 in.	1/8 in.	HLN4-2PF	0.34	0.156 (4.0)	2.25 (57.2)	1.13 (28.7)	1.09 (27.7)	0.50 (12.7)	1.75 (44.5)	11/16	3.17 (80.5)	5/32 (3.9)	0.24 (6.1)
	1/4 in.	1/4 in.	HLN4-4PF	0.34	0.156 (4.0)	2.25 (57.2)	1.13 (28.7)	1.09 (27.7)	0.50 (12.7)	1.75 (44.5)	11/16	3.17 (80.5)	5/32 (3.9)	0.24 (6.1)
	1/4 in.	1/4 in.	HLN6-4PF	0.85	0.250 (6.35)	3.12 (79.2)	1.56 (39.6)	1.34 (34.0)	0.63 (16.0)	2.50 (63.5)	1 1/32	3.79 (96.0)	3/16 (4.8)	0.28 (7.1)
	1/2 in.	1/2 in.	HLN6-8PF	0.85	0.250 (6.35)	3.12 (79.2)	1.56 (39.6)	1.34 (34.0)	0.63 (16.0)	2.50 (63.5)	1 1/32	3.79 (96.0)	3/16 (4.8)	0.28 (7.1)
Male NPT	1/4 in.	1/4 in.	HLN4-4PM	0.34	0.156 (4.0)	2.50 (63.5)	1.25 (31.7)	1.09 (27.7)	0.50 (12.7)	1.75 (44.5)	11/16	3.17 (80.5)	5/32 (3.9)	0.24 (6.1)
	1/2 in.	1/2 in.	HLN6-8PM	0.85	0.250 (6.35)	3.50 (88.9)	1.75 (44.4)	1.34 (34.0)	0.63 (16.0)	2.50 (63.5)	1 1/32	3.79 (96.0)	3/16 (4.8)	0.28 (7.1)
Male to Female NPT	1/4 in.	1/4 in.	HLN4-4PM-4PF	0.34	0.156 (4.0)	2.50 (63.5)	1.25 (31.7)	1.09 (27.7)	0.50 (12.7)	1.75 (44.5)	11/16	3.17 (80.5)	5/32 (3.9)	0.24 (6.1)
	1/2 in.	1/2 in.	HLN6-8PM-8PF	0.85	0.25 (6.35)	3.50 (88.9)	1.75 (44.4)	1.34 (34.0)	0.63 (16.0)	2.50 (63.5)	1 1/32	3.79 (96.0)	3/16 (4.8)	0.28 (7.1)
Tube Socket Weld	1/4 in.	1/4 in.	HLN4-4SW	0.34	0.156 (4.0)	2.25 (57.2)	1.13 (28.7)	1.09 (27.7)	0.50 (12.7)	1.75 (44.5)	11/16	3.17 (80.5)	5/32 (3.9)	0.24 (6.1)
Pipe Socket Weld	1/4 in.	1/4 in.	HLN4-4PSW	0.34	0.156 (4.0)	2.25 (57.1)	1.13 (28.7)	1.09 (27.6)	0.5 (12.7)	1.75 (44.5)	11/16	3.17 (80.5)	5/32 (3.9)	0.24 (6.1)

¹Note: Unilok, and Griplok tube fitting end connections are also available. To order, please see Tube Fitting End Connections on page 10. Example: LN4A-U4

² Dimensions are for reference only and are subject to change.

Options & Accessories

Stem Type

Select the stem type designator from the table below then add it to the part number. *Example: LN4V-D4-316*

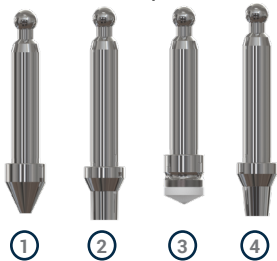

Stem Type	Designator
1. V-Type Shutoff Stem	V
2. Metering Stem	M
3. Soft Seal Stem (PCTFE)	K
4. Regulating Stem	R

Stem Packing

PTFE packing is standard on LN Series valves. To order high-temperature graphite or PEEK packing, add the designator from the table below after the stem type designator in the basic part number. **Note:** PEEK packing is available on LN6 and HLN6 valves only. *Example: LN6RP-D8-316*

Packing Material	Designator
Graphite	G
PEEK*	P

* Available for LN6 and HLN6 valves only.

Tube Fitting End Connections

SSP offers three tube fitting designs. Duolok tube fittings are standard. To select a different tube end, select the designator from the table below, then substitute it for the "D" in the part number. *Example: LN4R-U4-316 for Unilok tube fitting end connections.*

Design	Description	Designator
Duolok	2-Ferrule	D
Unilok	1-Ferrule	U
Griplok	2-Ferrule	G

Body Material

Select the valve body material required then add the designator to the valve basic part number. *Example: LN4R-4PF-M*

Material	Designator
316 Stainless Steel	-316
Alloy 400	-M
Alloy C-276	-HC

Sour Gas Service

Selecting valves for sour gas applications requires the consideration of several factors including the temperature, pH, partial pressure of H₂S, and whether the application is above or below ground. SSP offers four configurations to meet the requirements in ANSI/NACE MR0175/ISO 15156-3 and NACE MR0103/ISO 19745. To order valves for your sour gas applications add the designator below to the part number. *Example: LN6V-8PM-8PF-316-SG2*

Note: HLN Series valves are only available with SG1 and SG2 materials.

Designator	Wetted Part ¹	Non-Wetted	Body
SG1	Annealed 316 SS except body ²	316 SS	316 SS
SG2	Annealed 316 SS	316 SS	316 SS
SG3	Alloy 400/UNS S20910	316 SS	Alloy 400
SG4	Alloy 400/UNS S20910	Alloy 400	Alloy 400

¹Springs or other components may require other materials for functionality.

²Compression fittings and valve bodies with compression fitting ports are exempt from lower hardness requirements per ANSI/NACE MR0175/ISO 15156 and NACE MR0103/ISO 19745.

Special Cleaning

LN Series valves are available cleaned in compliance with ASTM G93 Level C and CGA G-4.1, *Cleaning Methods and Cleanliness Levels for Material and Equipment Used in Oxygen-Enriched Environments*. To specify, add -XP98 to the part number. *Example: LN6V-D6-316-XP98*

For more information please contact your local SSP distributor or SSP Customer Service.

Rebuild Kits

LN Series rebuild kits include a complete bonnet assembly, lubrication and instructions. To order select the valve size, stem type, kit, packing and body material designators from the table below.

Example: LN4R-RK-TFE-316

Valve Size*	Stem Type	Kit	Packing		Body Material		
			PTFE	-TFE	316 SS	-316	
LN4	Vee	V	-RK	Graphite	-G	Alloy 400	-M
LN6	Soft	K		PEEK	-PK	Alloy C-276	-HC
LN8	Regulating	R					
	Metering	M					

*For HLN Series valves add "H" before the valve size.

Gauge and Block & Bleed Valves

SSP offers locked bonnet needle gauge valves, rising plug gauge valves and block & bleed valves in 316 SS, Alloy 400 and Alloy C-276. See the Gauge and Block & Bleed Valves Catalog or mySSP.com for more information.



LN Series Special Orders

The Basic Part Numbers and Dimensions tables contain only the most popular valve configurations; many more are available. If the required valve configuration is not in the Basic Part Numbers and Dimensions tables, use the chart below to build part numbers for quotation purposes.

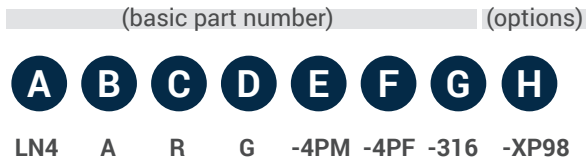

A SERIES / SIZE
 LN4 0.156 Orifice
 LN6 0.250 Orifice
 LN8 0.437 Orifice
 HLN4 0.156 Orifice
 HLN6 0.250 Orifice

B PATTERN
 Blank Straight
 A Angle

C STEM TYPE
 V Vee 316 SS
 M Metering 316 SS
 K Soft Seal, PCTFE
 R Regulating 316 SS

E + F INLET¹ + OUTLET¹

Type:	Fractional Sizes:	Metric Sizes:
D Duolok® Tube Fitting	2 1/8 in.	M6 6 mm
U Unilok® Tube Fitting	4 1/4 in.	M8 8 mm
G Griplik® Tube Fitting	6 3/8 in.	M10 10 mm
PF Female NPT	8 1/2 in.	M12 12 mm
PM Male NPT	12 3/4 in.	
SW Tube Socket Weld	16 1 in.	
PSW Pipe Socket Weld		
MST Male SAE Straight		
FST Female SAE Straight		

D PACKING MATERIAL
 Blank PTFE
 G Flexible Graphite
 P PEEK³

G BODY MATERIAL
 -316 316 SS
 -M Alloy 400
 -HC Alloy C-276

H OPTIONS²

SPECIAL CLEANING
 -XP98 Oxygen compatible lubricant, per ASTM G93, Level C and CGA G-4.1

SOUR GAS
 -SG ISO 15156 (NACE MR01-75)
 See page 10 for more information

¹ Tube fitting end connection part numbers are formatted Type followed by Size. Example: **D6**
 Pipe ends are formatted Size follow by Type. Example: **6PF**

If both ends are the same, use only one end connection designator. Example: LN8V-D8-316

² Add options designators to the end of the Base Part Number in alphabetical order.

³ Available for LN6 and HLN6 valves only.

⚠ Important Information

IMPROPER SELECTION OR IMPROPER USE OF THE PRODUCTS DESCRIBED HEREIN OR RELATED ITEMS CAN CAUSE PERSONAL INJURY AND PROPERTY DAMAGE. It is the sole responsibility of the system designers and users to properly select and use products for their specific applications. This document has been provided to users with technical expertise as a reference for further investigation to determine specific product needs relative to their design requirements.

⚠ Packing must be adjusted for application with working pressure higher than 1000 psig (69 bar) or if the valves have been exposed to high or low temperatures prior to installation. Instructions for packing adjustments are included with each valve. Valves that have not been actuated for extended periods of time may require greater actuation torque.

Testing

All LN Series valves are factory tested with Nitrogen to 1000 psig (69 bar) at 70°F (20°C). **Note: Packing adjustments may be required for applications with higher pressures and/or higher or lower process or environmental temperatures.**

Warranty

SSP valves are backed by the SSP Lifetime Limited Warranty. This warranty is available from your local distributor or at www.mySSP.com.

SSP

Founded 1926

Privately owned, third generation business

Modern single-site vertically integrated manufacturing facility

DFARS-compliant raw material

ISO 9001 quality management system

Lifetime Limited Warranty



*The Only
100% American Made
Instrument Valves & Fittings*

8250 Boyle Parkway • Twinsburg, OH 44087

330-425-4250 • www.mySSP.com

©2023 SSP Fittings Corp. All rights reserved.

LNPC-23A