

SSP

General Utility Ball Valves

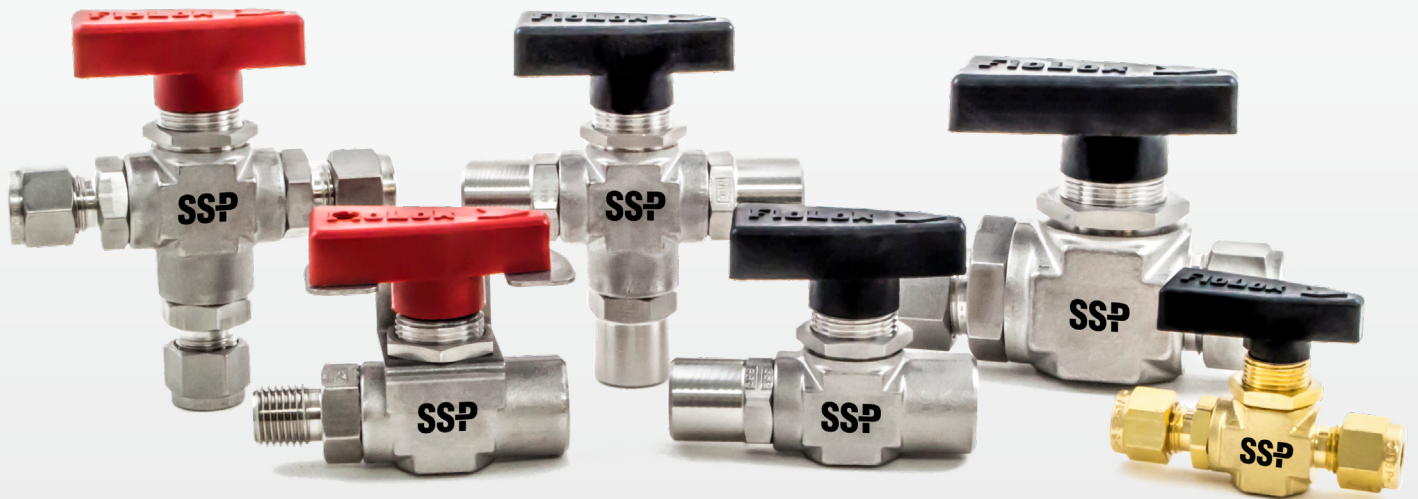

300 Series

- ✓ Working Pressure: up to 5000 psig (344 bar)
- ✓ End Connections: 1/8 to 3/4 in. (3 to 18 mm)
- ✓ Temperature Range: -40 to 350°F (-40 to 176°C)
- ✓ 2-way and 3-way valves

www.mySSP.com





At SSP, we are proud to be an American manufacturing success story.

100% of our products are made in America. All of our manufacturing is performed in our 165,000 sq. ft. facility located near Cleveland, Ohio. Our facility is the largest vertically integrated, single-site operation in the industry. In addition to manufacturing and assembly, we have closed die forging, tool & die design, product engineering and testing operations under the same roof with customer service and management.

Made in America is good business. Not only do we make everything in America, we use American suppliers too. Buying American allows us to have better quality control and a more reliable supply chain. We can work more closely within our walls and with our suppliers to improve quality, reduce costs, and shorten lead times, which means faster service and better products for you.

SSP Industry Standard Products.
Made Better.

TABLE of CONTENTS

Features	4	Ordering Information	6-8
Technical Information	5	Options & Accessories	9-10

300 Series General Utility Ball Valves

300 Series ball valves are designed for general utility, control, and small process applications up to 5000 psig (344 bar) and temperatures from -40 to 350°F (-40 to 176°C).

Two-way shut off valves and three-way diverting valves are available with 316 stainless steel or brass bodies. Valves are available in three sizes with 0.125, 0.250 and 0.438 in. orifices and standard end connections from 1/8 to 3/4 in. The end screw design allows them to be configured with mixed end connection types and sizes. The standard offering includes PTFE or PCTFE seats and FKM or nitrile O-rings.

The floating ball design allows upstream pressure to create a leak-tight seal on the downstream seat. O-ring stem seals eliminate the need for packing adjustments and reduce torque. 300 Series valves are offered in a wide range of end connection types and sizes and with a variety of seat and o-ring material combinations.

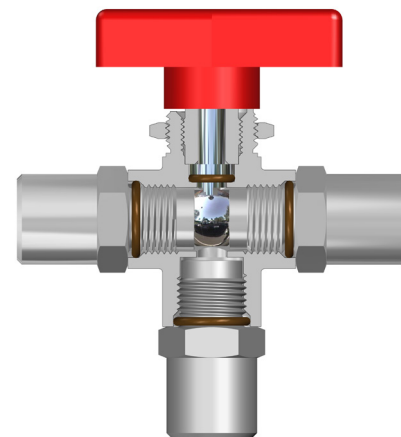
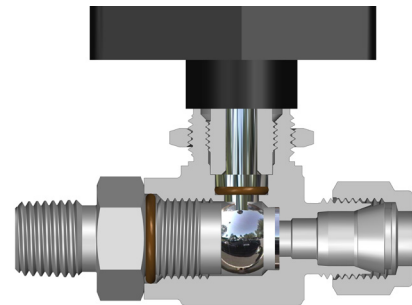

Applications

SSP 300 Series ball valves are used in a wide range of process and utility applications including compressed gas, water and lube systems.

Product Design

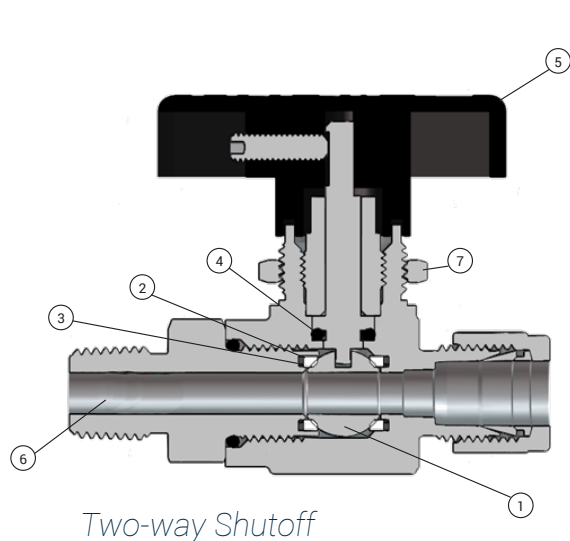

Two-way Shutoff

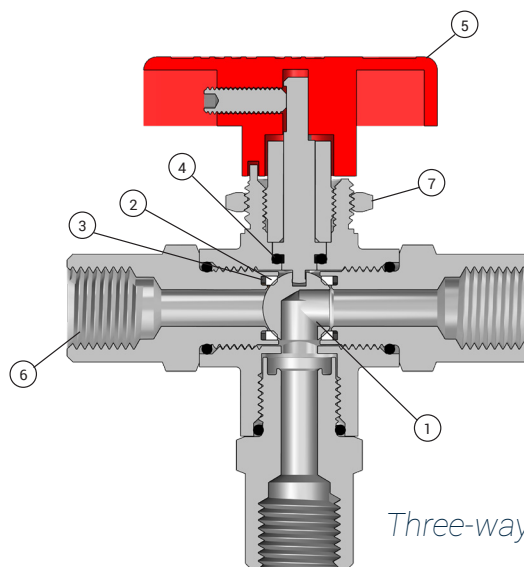

Three-way Diverting

- 1 MICRO FINISHED. FREE FLOATING BALL**
 - Seals with flow from either direction
 - Upstream pressure assists with downstream seal
 - Compensates for seat wear
 - Low operating torque
- 2 SEATS**
 - Tight bi-directional seal
 - PTFE / PCTFE / PEEK
- 3 BACKUP RING**
 - Supports and seals the valve seat
- 4 O-RING PACKING**
 - Does not require packing adjustment
 - Low operating torque
 - Wide range of o-ring materials for temperature and chemical compatibility
- 5 DIRECTIONAL HANDLE**

- 6 END SCREW DESIGN**
 - Allows a wide variety of mixed size and type end connection combinations
 - Easy Maintenance
- 7 PANEL MOUNTING**

Meets ASME B31.1 and B31.3 design pressure calculations

TESTING

All 300 Series valves are factory tested with Nitrogen to 1000 psig (69 bar) at 70°F (20°C).

WARRANTY

FloLok valves are backed by the SSP Lifetime Limited Warranty. This warranty is available from your local distributor or at www.mySSP.com.

Materials of Construction

ID	Component	316 SS	Brass
1	Body*	316 Stainless Steel	Brass
2	Panel Nut	316 Stainless Steel	Brass
3	Stem O-ring*	FKM	FKM
4	Stem*	316 Stainless Steel	316 Stainless Steel
5	Bonnet	316 Stainless Steel	Brass
6	Handle Set Screw	Stainless Steel	Stainless Steel
7	Handle	Nylon	Nylon
8	Connector O-ring*	FKM	FKM
9	Backup Rings*	FKM	FKM
10	Seats*	PTFE / PCTFE / PEEK	PTFE / PCTFE / PEEK
11	Ball*	316 Stainless Steel	316 Stainless Steel
12	Connector*	316 Stainless Steel	Brass

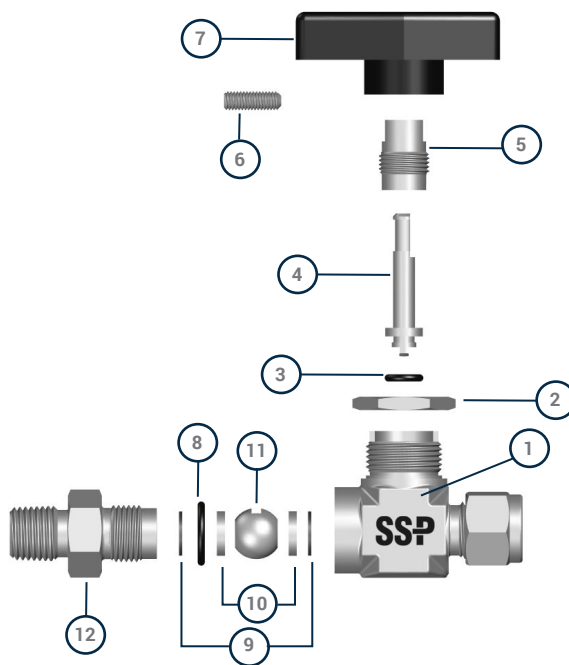

* Wetted components

Temperature - Pressure

The chart provides ratings for process temperatures.

Maximum work pressures

- PCTFE / PEEK: 5000 psig (344 bar)
- PTFE: 1500 psig (103 bar)

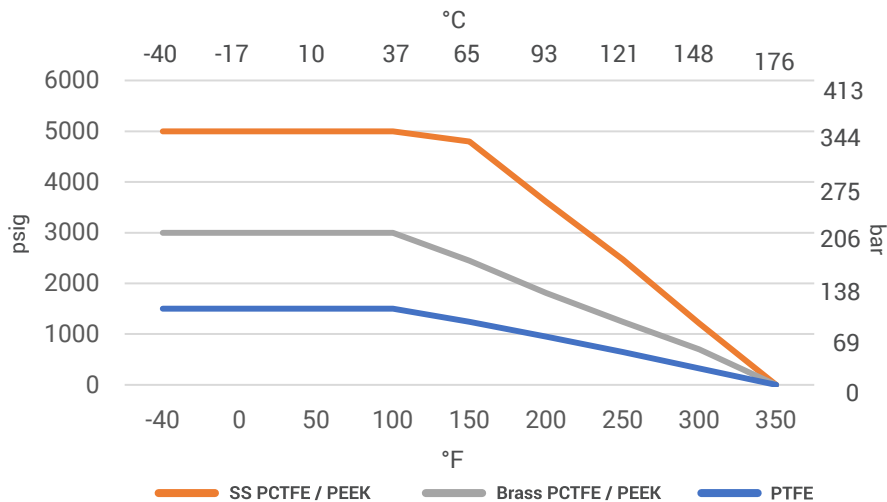

Ordering Information

Ordering Instructions

- ① Locate the Basic Part Number for the valve end connection type(s) and size(s). (See pages 6-8). *Example: 306.*
- ② PTFE seats are standard. For PCTFE seats add -K to the part number. For PEEK seats add -P to the part number. *Example: 306-K.*
- ③ Add the Body Material Designator to the part number. Add -316 for 316 stainless steel. Add -B for Brass. *Example: 306-K-316.*
- ④ Add designators for other options in alphabetical order (page 9). *Example 306-K-316-LOH-BN.*

Note: The Basic Ordering Numbers and Dimensions tables contain only the most popular valve configurations; more are available. If the required valve configuration is not in the Basic Part Numbers and Dimensions tables, contact your local Authorized SSP Instrumentation Distributor or Contact SSP Customer Service - customer.service@mySSP.com.

Two-Way Ball Valves

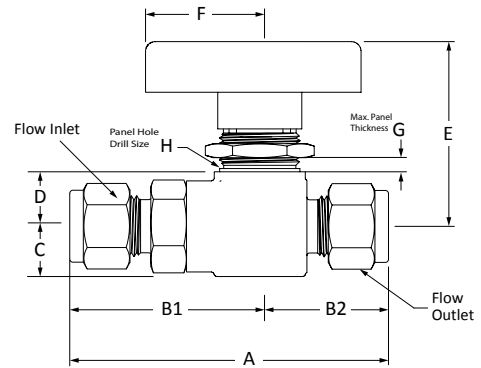
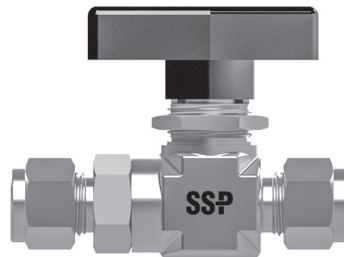

Part Numbers and Dimensions

End Connection			Basic Ordering Number	Orifice in. (mm)	Dimensions in. (mm) ²								
Type	Inlet Size	Outlet Size			A	B1	B2	C	D	E	F	G	H
Fractional Tube Fitting	1/8	1/8	350	0.093 (2.36)	2.21 (56.1)	1.24 (31.4)	0.97 (24.6)	0.40 (10.1)	0.38 (9.7)	1.33 (33.7)	0.94 (23.8)	0.19 (4.8)	25/32 (19.8)
	1/4	1/4	352	0.125 (3.18)	2.41 (61.2)	1.34 (34.0)	1.07 (27.1)	0.40 (10.1)	0.38 (9.7)	1.33 (33.7)	0.94 (23.8)	0.19 (4.8)	25/32 (19.8)
	1/4	1/4	312	0.187 (4.75)	2.76 (70.1)	1.62 (41.1)	1.14 (28.9)	0.47 (11.9)	0.51 (12.9)	1.71 (43.4)	1.06 (26.9)	0.19 (4.8)	25/32 (19.8)
	3/8	3/8	320	0.250 (6.35)	2.88 (73.1)	1.69 (42.9)	1.19 (30.2)	0.47 (11.9)	0.51 (12.9)	1.71 (43.4)	1.06 (26.9)	0.08 (4.8)	25/32 (19.8)
	1/2 ¹	1/2 ¹	322	0.250 (6.35)	3.10 (78.7)	1.80 (45.7)	1.30 (33.0)	0.47 (11.9)	0.51 (12.9)	1.71 (43.4)	1.06 (26.9)	0.19 (4.8)	25/32 (19.8)
	1/2	1/2	358	0.437 (11.10)	3.76 (95.5)	2.14 (54.3)	1.62 (41.1)	0.75 (19.1)	0.75 (19.1)	2.20 (55.8)	1.51 (38.3)	0.25 (6.4)	1 1/32 (26.1)
	3/4	3/4	359	0.437 (11.10)	3.76 (95.5)	2.14 (54.3)	1.62 (41.1)	0.75 (19.1)	0.75 (19.1)	2.21 (56.1)	1.51 (38.3)	0.25 (6.4)	1 1/32 (26.1)
Metric Tube Fitting	6	6	341	0.187 (4.75)	2.79 (70.9)	1.64 (41.7)	1.15 (29.2)	0.47 (11.9)	0.51 (12.9)	1.71 (43.4)	1.06 (26.9)	0.19 (4.8)	25/32 (19.8)
	8	8	342	0.250 (6.35)	2.83 (71.8)	1.66 (42.1)	1.17 (29.7)	0.47 (11.9)	0.51 (12.9)	1.71 (43.4)	1.06 (26.9)	0.19 (4.8)	25/32 (19.8)
	10	10	343	0.250 (6.35)	2.91 (73.9)	1.70 (43.1)	1.21 (30.7)	0.47 (11.9)	0.51 (12.9)	1.71 (43.4)	1.06 (26.9)	0.19 (4.8)	25/32 (19.8)
	12	12	344	0.250 (6.35)	3.11 (78.5)	1.80 (45.7)	1.31 (28.7)	0.47 (11.9)	0.51 (12.9)	1.71 (43.4)	1.06 (26.9)	0.19 (4.8)	25/32 (19.8)
	16	16	369	0.437 (11.10)	3.76 (95.5)	2.14 (54.4)	1.31 (28.7)	0.75 (19.1)	0.75 (19.1)	2.21 (56.1)	1.51 (38.3)	0.25 (6.4)	1 1/32 (26.2)
	18	18	367	0.437 (11.10)	2.14 (54.4)	2.14 (54.4)	1.62 (41.1)	0.75 (19.1)	0.75 (19.1)	2.21 (56.1)	1.51 (38.3)	0.25 (6.4)	1 1/32 (26.2)

¹Spacer included for panel mounting.

²Dimensions subject to change.

Two-Way Ball Valves



Part Numbers and Dimensions (cont.)

End Connection			Basic Ordering Number	Orifice in. (mm)	Dimensions in. (mm) ²								
Type	Inlet Size	Outlet Size			A	B1	B2	C	D	E	F	G	H
Fractional Tube Fitting to Female NPT	3/8	1/4	316	0.250 (6.35)	2.75 (69.8)	1.69 (42.9)	1.06 (26.9)	0.47 (11.9)	0.51 (12.9)	1.71 (43.4)	1.06 (26.9)	0.19 (4.8)	25/32 (19.8)
	1/2 ¹	1/2 ¹	323	0.437 (11.10)	3.56 (90.3)	2.15 (54.58)	1.41 (35.76)	0.75 (19.1)	0.75 (19.1)	2.21 (56.0)	1.51 (38.3)	0.14 (6.4)	1 1/32 (26.2)
Fractional Tube Fitting to Male NPT	1/4	1/4	303	0.250 (6.35)	2.68 (68)	1.62 (41.1)	1.06 (26.9)	0.47 (11.9)	0.51 (12.9)	1.71 (43.4)	1.06 (26.9)	0.19 (4.8)	25/32 (19.8)
	3/8	3/8	308	0.250 (6.35)	2.75 (68.9)	1.62 (41.1)	1.13 (28.7)	0.47 (11.9)	0.51 (12.9)	1.71 (43.4)	1.06 (26.9)	0.19 (4.8)	25/32 (19.8)
	1/2	1/2	362	0.437 (11.10)	3.58 (90.9)	2.14 (54.3)	1.44 (36.5)	0.75 (19.1)	0.75 (19.1)	2.21 (56.0)	1.51 (38.3)	0.25 (6.4)	1 1/32 (26.2)
Female NPT	1/8	1/8	351	0.125 (3.18)	2.03 (51.5)	1.15 (29.2)	0.88 (22.3)	0.40 (10.1)	0.38 (9.7)	1.33 (33.7)	0.94 (23.8)	0.19 (4.8)	19/32 (15.1)
	1/4	1/4	306	0.250 (6.35)	2.64 (67.0)	1.58 (40.1)	1.06 (26.9)	0.47 (11.9)	0.51 (12.9)	1.71 (43.4)	1.06 (26.9)	0.19 (4.8)	25/32 (19.8)
	3/8	3/8	319	0.437 (11.10)	3.26 (82.8)	2.01 (51.0)	1.25 (31.7)	0.75 (19.1)	0.75 (19.1)	2.21 (56.1)	1.51 (38.3)	0.25 (6.4)	1 1/32 (26.2)
	1/2	1/2	357	0.437 (11.10)	3.42 (86.8)	2.01 (51.0)	1.41 (35.8)	0.75 (19.1)	0.75 (19.1)	2.21 (56.1)	1.51 (38.3)	0.25 (6.4)	1 1/32 (26.2)
Female NPT to Fractional Tube Fitting	1/4	1/4	310	0.187 (4.75)	2.71 (68.8)	1.58 (40.1)	1.13 (28.7)	0.47 (11.9)	0.51 (12.9)	1.71 (43.4)	1.06 (26.9)	0.25 (6.4)	25/32 (19.8)
	1/4	3/8	315	0.250 (6.35)	2.78 (70.6)	1.58 (40.1)	1.20 (30.4)	0.47 (11.9)	0.51 (12.9)	1.71 (43.4)	1.06 (26.9)	0.25 (6.4)	25/32 (19.8)
Female NPT to Male NPT	1/8	1/8	355	0.125 (3.18)	1.93 (49.0)	1.15 (29.2)	0.78 (19.8)	0.40 (10.1)	0.38 (9.7)	1.33 (33.7)	0.94 (23.8)	0.25 (6.4)	19/32 (15.1)
Male NPT	1/8	1/8	353	0.125 (3.18)	1.83 (46.4)	1.05 (26.6)	0.78 (19.8)	0.40 (10.1)	0.38 (9.7)	1.33 (33.7)	0.94 (23.8)	0.25 (6.4)	19/32 (15.1)
	1/4	1/4	301	0.250 (6.35)	2.64 (67.0)	1.58 (40.1)	1.06 (26.9)	0.47 (11.9)	0.51 (12.9)	1.71 (43.4)	1.06 (26.9)	0.25 (6.4)	25/32 (19.8)
	3/8	3/8	314	0.250 (6.35)	2.71 (68.8)	1.58 (40.1)	1.13 (28.7)	0.47 (11.9)	0.51 (12.9)	1.71 (43.4)	1.06 (26.9)	0.25 (6.4)	25/32 (19.8)
	1/2	1/2	360	0.437 (11.1)	3.45 (87.6)	2.01 (51.1)	1.44 (36.5)	0.75 (19.1)	0.75 (19.1)	2.21 (56.1)	1.51 (38.3)	0.25 (6.4)	1 1/32 (26.2)
Male NPT to Fractional Tube Fitting	1/8	1/4	354	0.125 (3.18)	2.12 (53.9)	1.05 (26.5)	1.08 (27.3)	0.40 (10.2)	0.38 (9.7)	1.27 (32.3)	0.94 (23.9)	0.25 (6.4)	19/32 (15.1)
	1/4	1/4	304	0.187 (4.75)	2.72 (69.0)	1.58 (40.1)	1.14 (28.9)	0.44 (11.1)	0.44 (11.1)	1.71 (43.4)	1.06 (27.0)	0.25 (6.4)	25/32 (19.8)
	3/8	3/8	318	0.250 (6.35)	2.78 (70.5)	1.58 (40.1)	1.20 (30.4)	0.44 (11.1)	0.44 (11.1)	1.71 (43.4)	1.06 (27.0)	0.25 (6.4)	25/32 (19.8)
Male NPT to Female NPT	1/4	1/4	302	0.250 (6.35)	2.64 (67.1)	1.58 (40.1)	1.06 (26.9)	0.44 (11.1)	0.44 (11.1)	1.71 (43.4)	1.06 (27.0)	0.25 (6.4)	25/32 (19.8)
	3/8	3/8	321	0.437 (11.1)	3.06 (77.7)	1.81 (46.0)	1.25 (31.8)	0.75 (19.1)	0.75 (19.1)	2.21 (56.1)	1.51 (38.4)	0.25 (6.4)	1 1/32 (26.2)
	1/2	1/2	361	0.437 (11.1)	3.42 (86.9)	2.01 (51.1)	1.41 (35.8)	0.75 (19.1)	0.75 (19.1)	2.21 (56.0)	1.51 (38.4)	0.25 (6.4)	1 1/32 (26.2)

¹Spacer included for panel mounting.

²Dimensions subject to change.

Three-Way Ball Valves

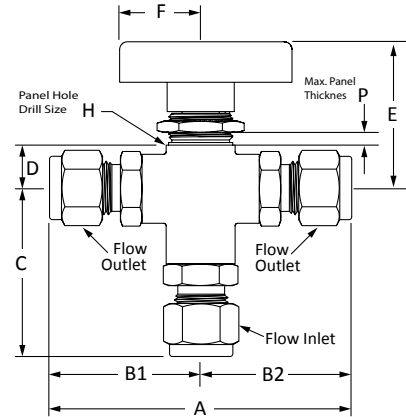

Part Numbers and Dimensions

End Connection			Basic Ordering Number	Orifice in. (mm)	Dimensions in. (mm) ²								
Type	Inlet Size	Outlet Size			A	B1	B2	C	D	E	F	G	H
Fractional Tube Fitting	1/8	1/8	350-3	0.093 (2.36)	2.48 (62.9)	1.24 (31.4)	1.24 (31.4)	1.42 (36.0)	0.38 (9.7)	1.33 (33.7)	0.94 (23.8)	0.19 (4.8)	19/32 (15.1)
	1/4	1/4	352-3	0.125 (3.18)	2.68 (68.0)	1.34 (34.0)	1.34 (34.0)	1.52 (38.6)	0.38 (9.7)	1.33 (33.7)	0.94 (23.8)	0.19 (4.8)	19/32 (15.1)
	1/4	1/4	312-3	0.187 (4.75)	3.24 (82.2)	1.62 (41.1)	1.62 (41.1)	1.81 (45.9)	0.51 (12.9)	1.71 (43.4)	1.06 (26.9)	0.19 (4.8)	25/32 (19.8)
	3/8	3/8	320-3	0.250 (6.35)	3.38 (85.8)	1.69 (42.9)	1.69 (42.9)	1.88 (47.7)	0.51 (12.9)	1.71 (43.4)	1.06 (26.9)	0.19 (4.8)	25/32 (19.8)
	1/2 ¹	1/2 ¹	322-3	0.250 (6.35)	3.60 (91.4)	1.80 (45.7)	1.80 (45.7)	1.99 (50.5)	0.51 (12.9)	1.71 (43.4)	1.06 (26.9)	0.19 (4.8)	25/32 (19.8)
	1/2	1/2	358-3	0.437 (11.10)	4.28 (108.7)	2.14 (54.3)	2.14 (54.3)	2.53 (64.2)	0.75 (19.1)	2.21 (56.1)	1.51 (38.3)	0.25 (6.4)	1 1/32 (26.2)
	3/4	3/4	359-3	0.437 (11.10)	4.28 (108.7)	2.14 (54.3)	2.14 (54.3)	2.54 (64.5)	0.75 (19.1)	2.21 (56.1)	1.51 (38.3)	0.25 (6.4)	1 1/32 (26.2)
Metric Tube Fitting	6	6	341-3	0.187 (4.75)	2.28 (57.9)	1.64 (41.7)	1.64 (41.7)	1.83 (46.5)	0.51 (12.9)	1.71 (43.4)	1.06 (26.9)	0.19 (4.8)	25/32 (19.84)
	8	8	342-3	0.250 (6.35)	3.34 (84.8)	1.67 (42.4)	1.67 (42.4)	1.86 (47.2)	0.51 (12.9)	1.71 (43.4)	1.06 (26.9)	0.19 (4.8)	25/32 (19.84)
	10	10	343-3	0.250 (6.35)	2.28 (57.9)	1.70 (43.2)	1.70 (43.2)	1.89 (48.0)	0.51 (12.9)	1.71 (43.4)	1.06 (26.9)	0.19 (4.8)	25/32 (19.84)
	12	12	344-3	0.250 (6.35)	3.60 (91.4)	1.80 (45.7)	1.80 (45.7)	1.99 (50.5)	0.51 (12.9)	1.71 (43.4)	1.06 (26.9)	0.19 (4.8)	25/32 (19.84)
	16	16	369-3	0.437 (11.10)	4.28 (108.7)	2.14 (53.3)	2.14 (53.3)	2.54 (64.0)	0.75 (19.1)	2.21 (56.1)	1.51 (38.25)	0.25 (6.4)	1 1/32 (26.19)
	18	18	367-3	0.437 (11.10)	4.28 (108.7)	2.14 (53.3)	2.14 (53.3)	2.54 (64.0)	0.75 (19.15)	2.21 (56.1)	1.51 (38.25)	0.25 (6.4)	1 1/32 (26.19)
Female NPT	1/4	1/4	306-3	0.250 (6.35)	3.16 (80.2)	1.58 (40.1)	1.58 (40.1)	1.77 (44.9)	0.51 (12.9)	1.71 (43.4)	1.06 (26.9)	0.19 (4.8)	25/32 (19.8)
	3/8	3/8	319-3	0.437 (11.1)	4.02 (102.1)	2.01 (51.1)	2.01 (51.1)	2.41 (61.2)	0.75 (19.1)	2.21 (56.1)	1.51 (38.3)	0.25 (6.4)	1 1/32 (26.2)
	1/2	1/2	357-3	0.437 (11.10)	4.02 (102.1)	2.01 (51)	2.01 (51)	2.41 (61.2)	0.75 (19.1)	2.21 (56.1)	1.51 (38.3)	0.25 (6.3)	1 1/32 (26.2)
Male NPT	1/8	1/8	353-3	0.125 (3.18)	2.10 (53.3)	1.05 (26.6)	1.05 (26.6)	1.23 (31.2)	0.38 (9.7)	1.33 (33.7)	0.94 (23.8)	0.19 (4.8)	19/32 (15.1)
	1/4	1/4	301-3	0.250 (6.35)	3.16 (80.2)	1.58 (40.1)	1.58 (40.1)	1.77 (44.9)	0.51 (12.9)	1.71 (43.4)	1.06 (26.9)	0.19 (4.8)	25/32 (19.8)
	3/8	3/8	314-3	0.250 (6.35)	3.16 (80.2)	1.58 (40.1)	1.58 (40.1)	1.77 (44.9)	0.51 (12.9)	1.71 (43.4)	1.06 (26.9)	0.19 (4.8)	25/32 (19.8)

¹Spacer included for panel mounting.

²Dimensions subject to change.

Options & Accessories

Seat Material

To specify seat material add the designator from the table below to the part number. Note: Valves with PTFE seats are supplied with black handles. Valves with PCTFE seat are supplied with red handles. To specify different colored handles see the Handle Options section.

Example: 312-3-K

Material	Designator
PTFE	Blank
PCTFE	-K
PEEK	-P

Body Material

Select the valve body material then add the designator to the basic part number.

Example: 306-K-316

Material	Designator
316 Stainless Steel	-316
Brass	-B

Tube Fitting End Connections¹

Duolok 2-ferrule tube ends are standard for 300 Series valves. To specify Unilok single ferrule or Griplok dual ferrule tube ends, add the designator from the table below to the part number.

Example: 312-3-K-316-U for Unilok tube end connections.

Design	Designator
Duolok	Blank
Unilok	-U
Griplok	-G

O-ring Material¹

O-ring materials are specified by adding the material designator from the table below after the body material designator. Example: 312-K-316-BN

Material	Designator
FKM	Blank
Nitrile	-BN

Mixed End Connections

300 Series valves are available with mixed end connection sizes and types. Contact SSP Customer Service for price and availability.

Example: 1/4 in. Duolok x 3/8 in. female NPT

Handle Options¹

Black nylon handles are standard for valves with PTFE seats. Red handles are standard for valves with PCTFE seats. To specify non-standard handle colors, add the designator from the table below to the part number after the body material designator.

Example: 312-K-316-BL

Handle Color	Designator
Black	-BK
Red	-RD
Green	-GR
Blue	-BL
Stainless Steel Bar	-SSBH
No Handle	-NH

Locking Devices¹

Factory installed locking handle hardware can be specified for any 300 Series valve by adding -LOH to the part number. Example: 312-K-316-LOH.

Locking device kits for field installation can be ordered using the part numbers in the table below.

Valve Size	Kit Part #
350, 351, 352, 353	350-LOHK
301, 302, 304, 306, 307, 310, 312, 314, 318, 320, 322	300-LOHK
315, 319, 323, 358, 357, 359, 360, 361, 362	370-LOHK

Special Cleaning¹

To specify special cleaning, add the designator from the table below to the part number.

Example: 312-K-316-XP98

Description	Designator
ASTM G93. Level C and CGA G-4.1	-XP98

¹Options are added in alphabetical order after the body material designator. Example: 312-3-K-316-BL-LOH-U-XP98

Options & Accessories

Maintenance Kits

Maintenance kits include: Seats, backup rings, stem O-ring and connector O-ring. To order, select the kit for the valve size, then add the seat material and O-ring seal material designators.

Example: **300-RK-T-V**

Valve Size	Kit Part #		Material Designator	
	2-way	3-way	Seat	O-ring
350, 351, 352, 353	350-RK	350-3-RK		
301, 302, 304, 306, 307, 310, 312, 314, 318, 320, 322	300-RK	300-3-RK	-T PTFE -K PCTFE -P PEEK	-V FKM -BN NBR
315, 319, 323, 358, 357, 359, 360, 361, 362	370-RK	370-3-RK		

Replacement Handles

To order replacement handles, locate the kit part number for the valves size, then add the color designator from the Handle Options table.

Example: **350-7K-BK**

Valve Size	Kit Part #
350, 351, 352, 353	350-7K
301, 302, 304, 306, 307, 310, 312, 314, 318, 320, 322	300-7K
315, 319, 323, 358, 357, 359, 360, 361, 362	370-7K



Important Information

IMPROPER SELECTION OR IMPROPER USE OF THE PRODUCTS DESCRIBED HEREIN OR RELATED ITEMS CAN CAUSE PERSONAL INJURY AND PROPERTY DAMAGE. It is the sole responsibility of the system designers and users to properly select and use products for their specific applications. This document has been provided to users with technical expertise as a reference for further investigation to determine specific product needs relative to their design requirements. 300 series ball valves should only be used in the full on or full off position. Throttling may damage the valve.

Valves that have not been actuated for extended periods of time may require greater actuation torque.

Duolok®. Unilok®. Griplok®. FloLok® and TruFit® are registered trademarks of SSP Fittings Co.

More SSP Products



Tube Fittings

Duolok® and Griplok® (two-ferrule) and Unilok® (single-ferrule) tube fittings ensure leak-tight installation when intermixed with Swagelok®, Hoke® Gyrolok®, and Parker® CPI™ fittings, provided they are used in accordance with SSP Fittings' published installation and service recommendations.



Valves

The SSP valve offering includes ball, check, metering, needle, toggle, plug, bleed, and purge valves for pressures up to 10,000 psig.



Quick Connects

SSP offers single-end shutoff, double-end shutoff, and full-flow quick connects for instrumentation and process applications.



Pipe Fittings

TruFit and TruFit 10K pipe fittings are available in a wide range of weld, threaded and flared connections.



Filters

SSP in-line and tee-type filters trap particles to clean sample fluids and protect sensitive process and analytical instrumentation components and equipment.



Tools & Accessories

SSP TurnPro professional hand tools, power tools and installation training make quality tube system installation faster and easier.



SSP

Founded 1926

Privately owned, third generation business

Modern single-site vertically integrated manufacturing facility

DFARS-compliant raw material

ISO 9001 quality management system

ISO 17025 testing laboratory

Lifetime Limited Warranty



8250 Boyle Parkway • Twinsburg, OH 44087

330-425-4250 • www.mySSP.com