

Locked Bonnet Gauge and Block & Bleed Valves



LNG & LPG Series

- Working Pressures up to 6000 psig (413 bar)
- Needle Gauge Valves
- Temperature Range from -100 to 1200°F
(-73 to 648°C)
- Block and Bleed Valves
- Flow Coefficients up to 2.18
- Rising Plug Gauge Valves



At SSP, we are proud to be an American manufacturing success story.

100% of our products are made in America. All of our manufacturing is performed in our 165,000 sq. ft. facility located near Cleveland, Ohio. Our facility is the largest vertically integrated, single-site operation in the industry. In addition to manufacturing and assembly, we have closed die forging, tool & die design, product engineering and testing operations under the same roof with customer service and management.

Made in America is good business. Not only do we make everything in America, we use American suppliers too. Buying American allows us to have better quality control and a more reliable supply chain. We can work more closely within our walls and with our suppliers to improve quality, reduce costs, and shorten lead times, which means faster service and better products for you.

Support where it counts. SSP products and services are supported by more than 4000 people and 350 distributor locations around the globe. For a distributor near you, contact SSP Customer Service or visit www.mySSP.com/distributors.

SSP Industry Standard Products
Made Better

Table of Contents

Overview	3	Rising Plug Gauge Valves	10
Needle Gauge and Block & Bleed Valves....	4	Product Design	10
Product Design	4	Technical Information	11
Technical Information	5	Ordering Information	12-15
Ordering Information	6-9		

LNG & LPG Series Locked Bonnet Gauge and Block & Bleed Valves

Needle and Rising Plug Gauge Valves

SSP offers needle and rising plug gauge valves in three port and block and bleed designs. Block and bleed valves are available with packed bonnet or non-packed vent valves. All packed bonnets feature live-loaded packing below the stem threads and non-rotating stems for better cycle life, lower maintenance and leak-tight shut off even in severe service conditions.

Safer Bonnet Design

In the locked bonnet design, the bonnet is screwed into the valve body to seal on a metal to metal surface. The bonnet is locked in place with a ring, which is secured with a separate screw. This prevents accidental disassembly during packing adjustment, loosening due to vibration, or unscrewing of the bonnet by continuing to rotate the stem after it is fully open. The back-seating lower stem allows inline packing adjustments to be made more safely.

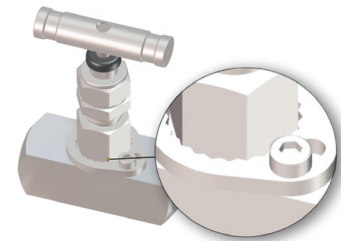

LN Series locked bonnet design

Better Non-Rotating Stem Tip Design

Unlike non-rotating ball stem tips, SSP gauge valves are designed with a non-rotating lower stem that prevents seat damage and reduces wear to the seat and packing. The threaded upper stem and stem pivot are located above the packing to prevent system media from attacking the threads, washing away thread lubricants or clogging, or corroding the non-rotating stem mechanism. This ensures that the stem tip will not rotate even in severe conditions.

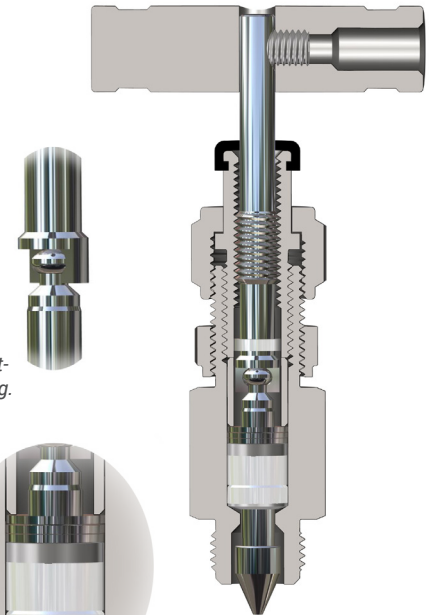

Non-rotating lower stem pivot is protected above the packing.

Leak-Tight Reliability and Low Maintenance

The tighter your system, the better your data. SSP gauge valves are designed with live loaded packing that provides a dynamic leak-tight stem seal, which compensates for changes in pressure, temperature and packing wear.

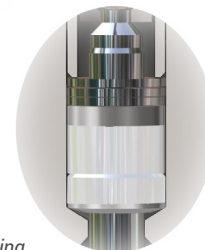

Live-Loaded Chevron Packing below the threads.

LNG Series Product Design

LNG Series gauge valves are designed to allow replacement and calibration of pressure gauges, pressure transmitters, and other instruments. LNG Series gauge and block and bleed valves are used in demanding oil & gas exploration, refining, high pressure instrumentation, test stands, steam systems and many other applications having pressures up to 6000 psig (413 bar), temperatures from -100 to 1200°F (-73 to 648°C), high vibration, and frequent cycling.

- 1 LIVE LOADED CHEVRON PACKING**
- Reduces need for packing adjustments
 - Compensates for wear
 - Compensates for pressure and temperature changes
 - Packing support prevents extrusion of the packing
 - Flexible graphite packing is available for high-temperature applications

- 2 BACK SEATING STEM**
- Easy access to packing bolt – nothing to disassemble
 - Allows in line packing adjustment in pressurized system
 - Isolates the packing when the valve is in the fully open position
 - Makes in-line packing adjustment safer

- 3 HARDENED NON-WETTED STEM THREADS**
- Hardened 17-4 PH stainless steel
 - High cycle life
 - Retain lubricants for easy operation and longer cycle life

- 4 DUST CAP**
- Prevents contamination of the stem threads from the environment
 - Colored vent and isolation caps for safety

- 5 BONNET LOCK PLATE**
- Locks bonnet in place to prevent accidental disassembly
 - Positive lock is superior to pin-type retainers

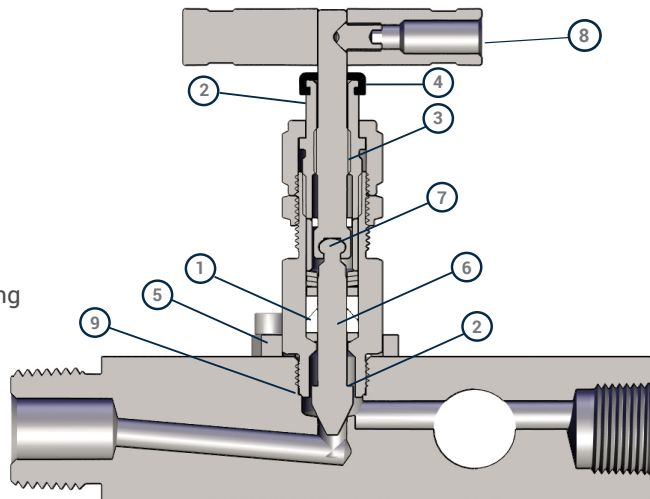

- 6 NON ROTATING LOWER STEM**
- Prevents damage to the seat and stem tip for repetitive leak-tight sealing even in severe environments
 - Reduces packing maintenance because the stem does not rotate within the packing
 - Vee-type, soft-seal shutoff, regulating, and metering stem tips are available
 - Chrome-plated, strain-hardened 316 SS

- 7 NON-WETTED, STEM PIVOT INTERLOCK**
- Prevents system media from infiltrating and seizing up the stem joint

- 8 DURABLE STAINLESS STEEL HANDLE**
- Large ergonomic handle for easier actuation

- 9 METAL TO METAL BONNET SEAL**
- Higher temperatures and chemical compatibility

Meets ASME B31.1 and B31.3 design pressure calculations

Materials of Construction

ID	Component	Body Material		
		316 SS	Alloy 400	Alloy C-276
1	Handle Screw	316 SS/A276		
2	T-Bar Handle	303/A582		
3	Cap	NBR/D2000		
4	Packing Nut	316 SS/A276		
5	Packing Bolt	316 SS/A276		
6	Stem Guide	PEEK		
7	Upper Stem	17-4 PH/A564		
8	Packing Spacer	316 SS/A276		
9	Packing Springs	301/A666		
10	Packing Washer	316 SS/A276		
11*	Upper Packing	PTFE/D1710, Flexible Graphite		
12*	Lower Packing	PTFE/D1710, Flexible Graphite		
13*	Packing Support	316 SS/A276	Alloy 405/ B164	Alloy C-276/B574
14*	Vee-Type Stem	Chrome-plated 316 SS/A276	Chrome-Plated Alloy 400/B164	Chrome Plated Alloy C-276/B574
15	Socket Screw	316 SS/A276		
16	Panel Nut	316 SS/A276		
17	Bonnet Lock	316 SS/A276		
18*	Bonnet	316 SS/A479	Alloy 405/B164	Alloy C-276/B574
19*	Body	316 SS/A479	Alloy 400/B164	Alloy C-276/B574
	Packing Lubricant	Fluorocarbon-based lubricant		
	Thread Lubricant	Fluorocarbon-based lubricant with Tungsten Disulfide		

*Wetted components

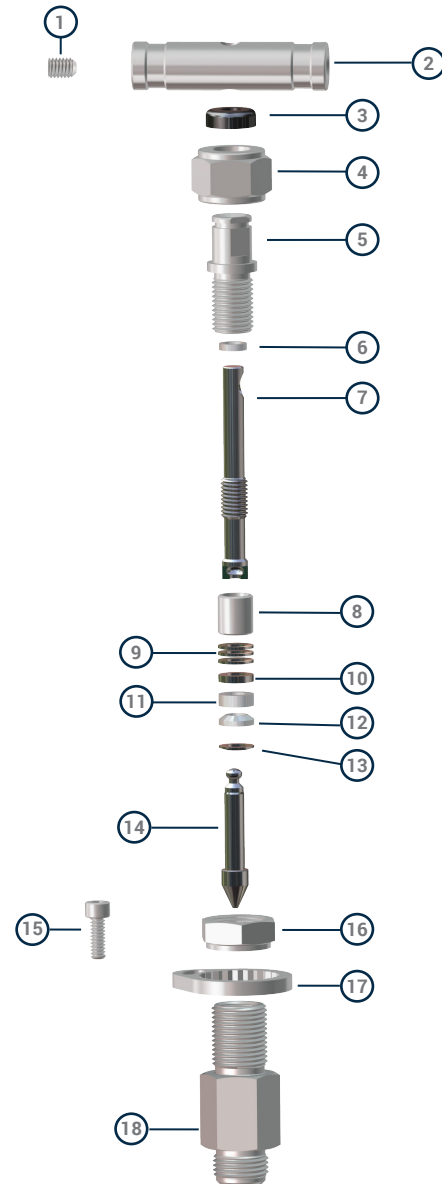

Temperature-Pressure

Data reflect temperature ratings from both process and environmental sources.

- Pressure ratings on the graph are based on valves with graphite packing.
- Valves with PTFE packing have a maximum temperature of 450°F (232°C).
- Valve with PCTFE stem tips have a maximum temperature of 200°F (93°C).

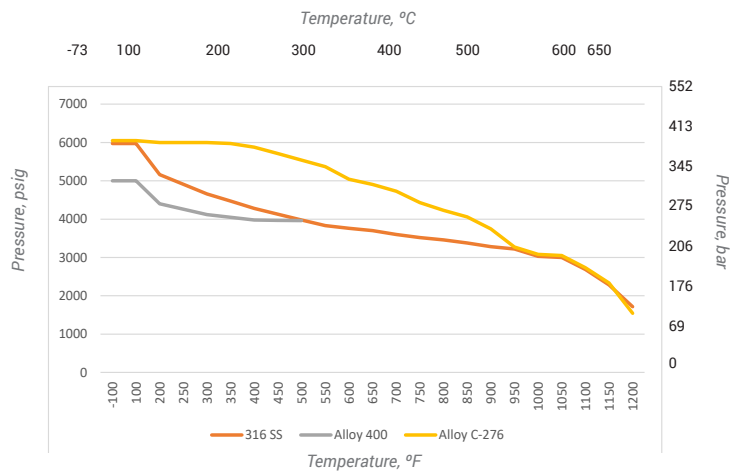

Ordering Information

To order, follow the steps below.

- 1 Locate type of valve required in the Basic Part Number & Dimensions tables on pages 6 & 7.
Example: **LNG Series**
- 2 Locate the basic part number with the required end connection type, end connection size.
Example: **LNG6V-8PM-8PF**
- 3 Add the Body Material Designator. Use -316 for 316 Stainless Steel, -M for Alloy 400 or -HC for Alloy C-276. Example: **LNG6V-8PM-8PF-316**
- 4 Add designators for packing, cleaning and other options in alphabetical order after the material designator. (See page 8) Example: **LNG6VG-8PM-8PF-316-SG2**

NOTE: The Part Numbers and Dimensions Tables contain the most popular part numbers. For configurations that are not in the catalog, see the Special Order chart on page 9.

LNG Series

LNG Series are 3-port needle gauge valves with LN Series isolation bonnets and three outlet ports.

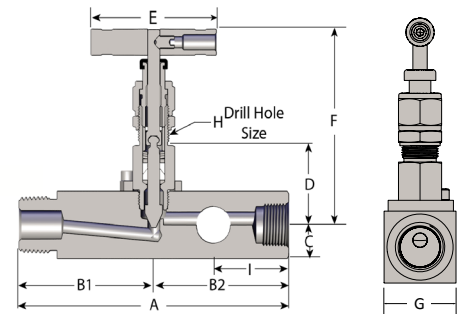
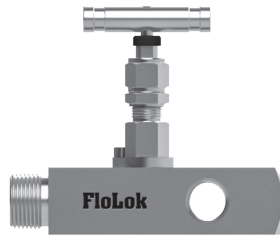

Basic Part Numbers and Dimensions

End Connections ¹			Basic Part Number	Cv	Orifice in. (mm)	Dimensions ³									
Type	Inlet ² Size	Outlet ² Size				A	B1	B2	C	D	E	F	G	H	I
Male NPT to Female NPT	1/2	1/2	LNG6V-8PM-8PF	0.86	0.25	5.38 (136.6)	2.97 (74.8)	2.41 (61.2)	0.625 (15.9)	1.46 (37.1)	2.50 (63.5)	3.95 (100.3)	1.25 (31.8)	11/16 or 23/32	1.50 (38.1)
	1/2	1/2	LNG6V-8PML4-8PF	0.86	0.25	7.25 (184.2)	4.93 (125.2)	2.32 (58.9)	0.625 (15.9)	1.46 (37.1)	2.50 (63.5)	3.95 (100.3)	1.25 (31.8)	11/16 or 23/32	1.50 (38.1)
	1/2	1/2	LNG6V-8PML6-8PF	0.86	0.25	9.25 (235)	6.93 (176)	2.32 (58.9)	0.625 (15.9)	1.46 (37.1)	2.50 (63.5)	3.95 (100.3)	1.25 (31.8)	11/16 or 23/32	1.50 (38.1)
	3/4	1/2	LNG6V-12PM-8PF	0.86	0.25	5.38 (136.6)	2.97 (74.8)	2.41 (61.2)	0.625 (15.9)	1.46 (37.1)	2.50 (63.5)	3.95 (100.3)	1.25 (31.8)	11/16 or 23/32	1.50 (38.1)
	3/4	1/2	LNG6V-12PML4-8PF	0.86	0.25	7.25 (184.2)	4.93 (125.2)	2.32 (58.9)	0.625 (15.9)	1.46 (37.1)	2.50 (63.5)	3.95 (100.3)	1.25 (31.8)	11/16 or 23/32	1.50 (38.1)
	3/4	1/2	LNG6V-12PML6-8PF	0.86	0.25	9.25 (235)	6.93 (176)	2.32 (58.9)	0.625 (15.9)	1.46 (37.1)	2.50 (63.5)	3.95 (100.3)	1.25 (31.8)	11/16 or 23/32	1.50 (38.1)
Pipe Butt Weld to Female NPT	1/2	1/2	LNG6V-8PBWL4-8PF	0.86	0.25	7.25 (184.2)	4.93 (125.2)	2.32 (58.9)	0.625 (15.9)	1.46 (37.1)	2.50 (63.5)	3.95 (100.3)	1.25 (31.8)	11/16 or 23/32	1.50 (38.1)
	1/2	1/2	LNG6V-8PBWL6-8PF	0.86	0.25	9.25 (235)	6.93 (176)	2.32 (58.9)	0.625 (15.9)	1.46 (37.1)	2.50 (63.5)	3.95 (100.3)	1.25 (31.8)	11/16 or 23/32	1.50 (38.1)
	3/4	1/2	LNG6V-12PBWL4-8PF	0.86	0.25	7.25 (184.2)	4.93 (125.2)	2.32 (58.9)	0.625 (15.9)	1.46 (37.1)	2.50 (63.5)	3.95 (100.3)	1.25 (31.8)	11/16 or 23/32	1.50 (38.1)
	3/4	1/2	LNG6V-12PBWL6-8PF	0.86	0.25	9.25 (235)	6.93 (176)	2.32 (58.9)	0.625 (15.9)	1.46 (37.1)	2.50 (63.5)	3.95 (100.3)	1.25 (31.8)	11/16 or 23/32	1.50 (38.1)
Pipe Socket Weld to Female NPT	1/2	1/2	LNG6V-8PSWL4-8PF	0.86	0.25	7.25 (184.2)	4.93 (125.2)	2.32 (58.9)	0.625 (15.9)	1.46 (37.1)	2.50 (63.5)	3.95 (100.3)	1.25 (31.8)	11/16 or 23/32	1.50 (38.1)
	1/2	1/2	LNG6V-8PSWL6-8PF	0.86	0.25	9.25 (235)	6.93 (176)	2.32 (58.9)	0.625 (15.9)	1.46 (37.1)	2.50 (63.5)	3.95 (100.3)	1.25 (31.8)	11/16 or 23/32	1.50 (38.1)
	3/4	1/2	LNG6V-12PSWL4-8PF	0.86	0.25	7.25 (184.2)	4.93 (125.2)	2.32 (58.9)	0.75 (19.1)	1.585 (40.3)	2.50 (63.5)	4.08 (103.6)	1.50 (38.1)	11/16 or 23/32	1.50 (38.1)
	3/4	1/2	LNG6V-12PSWL6-8PF	0.86	0.25	9.25 (235)	6.93 (176)	2.32 (58.9)	0.75 (19.1)	1.585 (40.3)	2.50 (63.5)	4.08 (103.6)	1.50 (38.1)	11/16 or 23/32	1.50 (38.1)

¹For valve configurations not shown on this table, please use the Special Order guide on page 9 or contact SSP Customer Service.

²All vent ports are 1/2 in. female NPT. To order a different size port, use the Special Order guide on page 9 or contact SSP Customer Service.

³Valve dimensions are subject to change.

LNBB Series

LNBB Series are block and bleed valves featuring LN Series bonnets for both isolation and bleed functions to allow safer maintenance of instruments in systems with hazardous media.

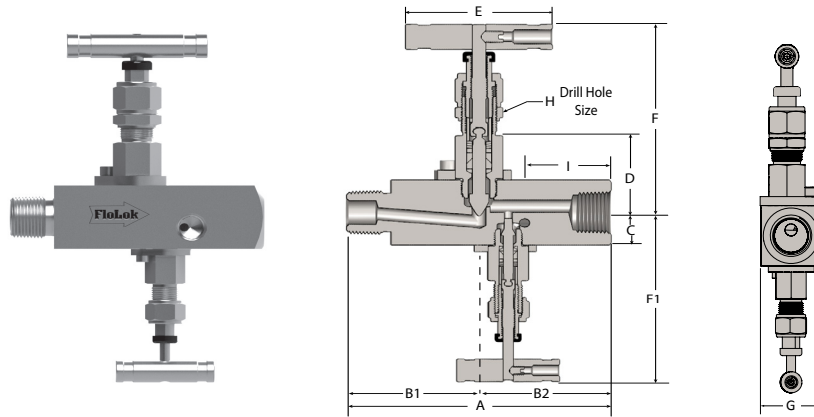

Basic Part Numbers and Dimensions

End Connections ¹			Basic Part Number	Cv	Orifice in. (mm)	Dimensions ³										
Type	Inlet Size	Outlet ² Size				A	B1	B2	C	D	E	F	F1	G	H	I
Male to Female NPT	1/2 in.	1/2 in.	LNBB64V-8PM-8PF	0.86	0.25 (6.35)	4.50 (114.3)	2.25 (57.2)	2.25 (57.2)	0.625 (15.9)	1.46 (37.1)	2.5 (63.5)	3.95 (100.3)	3.35 (85.0)	1.25 (31.8)	5/8 or 9/16	1.30 (33.0)
	1/4 in.	1/4 in.	LNBB64V-4PM-4PF	0.86	0.25 (6.35)	4.50 (114.3)	2.25 (57.2)	2.25 (57.2)	0.625 (15.9)	1.46 (37.1)	2.5 (63.5)	3.95 (100.3)	3.35 (85.0)	1.25 (31.8)	5/8 or 9/16	1.30 (33.0)
Male NPT	1/2 in.	1/2 in.	LNBB64V-8PM	0.86	0.25 (6.35)	4.88 (124)	2.44 (62)	2.44 (62)	0.625 (15.9)	1.46 (37.1)	2.5 (63.5)	3.95 (100.3)	3.35 (85.0)	1.25 (31.8)	5/8 or 9/16	1.50 (38.1)
	1/4 in.	1/4 in.	LNBB64V-4PM	0.86	0.25 (6.35)	4.88 (124)	2.44 (62)	2.44 (62)	0.625 (15.9)	1.46 (37.1)	2.5 (63.5)	3.95 (100.3)	3.35 (85.0)	1.25 (31.8)	5/8 or 9/16	1.50 (38.1)

¹For valve configurations not shown on this table, please use the Special Order table on page 9 or contact SSP customer service.

²All vent ports are 1/4 in. female NPT. To order a different size port, contact SSP Customer Service or your local authorized SSP distributor.

³Valve dimensions are subject to change.

LNBP Series

LNBP Series are block and bleed valves featuring a LN Series isolation bonnet and an unpacked integral bleed port to allow maintenance of instruments having non-hazardous media.

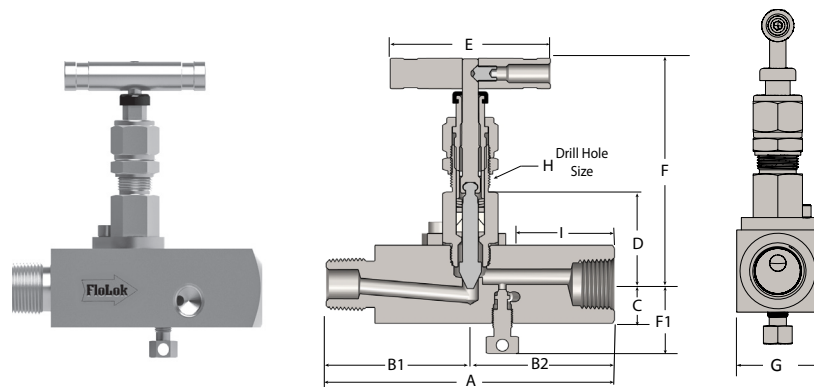

Basic Part Numbers and Dimensions

End Connections ¹			Basic Part Number	Cv	Orifice in. (mm)	Dimensions ³										
Type	Inlet Size	Outlet ² Size				A	B1	B2	C	D	E	F	F1	G	H	I
Male to Female NPT	1/2 in.	1/2 in.	LNBP6V-8PM-8PF	0.86	0.25	4.50 (114.3)	2.25 (57.2)	2.25 (57.2)	0.625 (15.9)	1.46 (37.1)	2.5 (63.5)	3.95 (100.3)	1.15 (29.2)	1.25 (31.8)	11/16 or 23/32	1.30 (33.0)

¹For valve configurations not shown on this table, please use the Special Order table on page 9 or contact SSP customer service.

²All vent ports are 1/4 in. female NPT. To order a different size port, contact SSP Customer Service or your local authorized SSP distributor.

³Valve dimensions are subject to change.

Options & Accessories

Flexible Graphite Packing

PTFE packing is standard for LN Series valves. To specify flexible graphite high-temperature packing, place G after the stem type designator in the basic part number.

Example: *LNG8VG-D8-316*

Body Material

Select the valve body material required and add the designator to the valve basic part number.

Example: *LNG4V-4PF-M*

Material	Designator
316 Stainless Steel	-316
Alloy 400	-M
Alloy C-276	-HC

Bleed Valves and Plugs

Bleed valves and pipe plugs can be ordered installed or shipped loose with gauge valves. To order installed bleed valves and plugs use the Gauge Port Order illustration to place the designators from the table below in the position where they are to be installed.

Example: *LNG6V-8PM-8PF-BV1T-PP-316*

To order bleeds valve and plugs shipped loose, place the designator after the material designation in alphabetical order with other options. Example *LNG6V-8PF-316-BV1T-PP*.

Component	Designator	
	Valve	w/ T-Handle
Bleed Valve with no tube stub	-BV1	-BV1T
Bleed Valve with tube stub port	-BV2	-BV2T
Bleed Valve with barb port	-BV3	-BV3T
Hex Plug	-PP	-
Hollow Hex Plug	-HHP	-

Gauge Valve Port Order

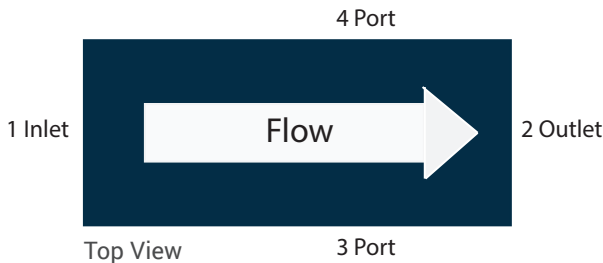

Note: LNBB and LNBP Series bleed ports are 1/4 in. NPT only.

Tube End Connections

In addition to end connections offered in the Basic Part Number and Dimensions table, SSP can provide Duolok, Griplok and Unilok tube end connections. To order special end connections, see the Special Order section on page 9 or contact SSP Customer Service.

Lagging

To order valves with extended inlets (lagging), select the designator from the table below.

Example: *LNG8V-8PML6-8PF-316*

Length	Designator
None	Blank
L4	4 in.
L6	6 in.

Replacement Dust Caps

Black dust caps are standard on LNG Series multi-port gauge valves. LNBB Series dust caps are shipped with green caps on isolation valves and red caps on vent valves. Note: Maximum temperature for dust caps is 250° F (121° C)

Valve Type	Part Number
Black	L6-3C-NBR
Green	L6-3C-D-GR
Red	L6-3C-D-RD

Replacement Handles

To order replacement handles use the part number from the table below.

Valve Type	Part Number
Isolation	L6-7A-303
Vent	L4-7A-303

Special Cleaning

LNG Series valves are available cleaned in compliance with ASTM G93 Level C and CGA G-4.1, *Cleaning Methods and Cleanliness Levels for Material and Equipment Used in Oxygen-Enriched Environments*. To specify, add -XP98 to the part number.

Example: *LP6D-8PF-316-XP98*

For more information about other types of special cleaning, please contact your local SSP distributor or SSP Customer Service.

Sour Gas Service

Selecting valves for sour gas applications requires the consideration of several factors including the temperature, pH, partial pressure of H₂S, and whether the application is above or below ground. SSP offers four configurations to meet the requirements in ANSI/NACE MR0175/ISO 15156-3 and NACE MR0103/ISO 19745. To order valves for your sour gas applications add the designator below to the part number. *Example: LNG6V-8PM-8PF-316-SG2*

Designator	Wetted Part ¹	Non-Wetted	Body
SG1	Annealed 316 SS except body ²	316 SS	316 SS
SG2	Annealed 316 SS	316 SS	316 SS
SG3	Alloy 400/UNS S20910	316 SS	Alloy 400
SG4	Alloy 400/UNS S20910	Alloy 400	Alloy 400

¹Springs or other components may require other materials for functionality.

²Compression fittings and valve bodies with compression fitting ports are exempt from lower hardness requirements per ANSI/NACE MR0175/ISO 15156 and NACE MR0103/ISO 19745.

Maintenance Kits

LN Series rebuild kits are preassembled and ready to install in the valve. Kits include complete bonnet assembly. To order rebuild kits select the part number from the table below, then add the body material designator to the part number .

Example: LN6-RK-TFE-316

Valve Type	Packing	Part Number
Isolation	PTFE	LN6-RK-TFE
Isolation	Flexible Graphite	LN6-RK-G
Vent	PTFE	LN4-RK-TFE
Vent	Flexible Graphite	LN4-RK-G

Special Orders

LN Series Gauge and Block & Bleed Valves

The Basic Part Numbers and Dimensions tables contain only the most popular valve configurations; many more are available. If the required valve configuration is not in the Basic Part Numbers and Dimensions tables, use the chart below to build part numbers for quotation purposes.

Series	Size	Stem	Packing	Inlet	Lagging	Outlet	Ports	Body	Options
A	B	C	D	E	F	G	H	I	J
LNG	6	V	G	-8PM	L4	-8PM	-8PF-8PF	-316	-SG2

A

SERIES

LNBP Block and Bleed Integral Bleed (unpacked)
 LNBB Block and Bleed vent to port (packed bleed valve)
 LNG 3-port Gauge

B

SIZE

6 0.250 Orifice

C

STEM TYPE

V Vee
 K PCTFE
 R Regulating
 M Metering

D

PACKING MATERIAL

Blank PTFE
 G Flexible Graphite

F

LAGGING

None Blank
 L4 4 in.
 L6 6 in.

I

BODY MATERIAL

-316 316 SS
 -M Alloy 400
 -HC Alloy C-276

E

G

H

INLET/OUTLET/PORT^{2,3}

Types	Sizes
D* Duolok Tube Fitting	4 1/4 in.
U* Unilok Tube Fitting	8 1/2 in.
G* Griplok Tube Fitting	12 3/4 in.
*PF Female NPT	
*PM Male NPT	
*PSW Female Pipe Socket Weld	
*PBW Male Pipe Socket/Butt Weld	
*SW Tube Socket Weld	
* To designate a connection size and type, replace the * with the size designator. Example: 4PM	

J

OPTIONS¹

SPECIAL CLEANING

-XP98 Oxygen compatible lubricant, per ASTM G93, Level C and CGA G-4.1

BLEED VALVES AND PLUGS

See ordering instructions for bleed valves and plugs on page 8.

SOUR GAS

-SG1 See the specifications at the top
 -SG2 of this page
 -SG3
 -SG4

¹ Add options designators to the end of the Base Part Number in alphabetical order.

² If both ends are the same, use only one end connection designator. Example: LNG8V-8PF-316. If the ends do not match, designate the inlet then the outlet. Example: LNG6V-8PM-8PF-316

³ Gauge ports are 1/4 or 1/2 in. female NPT only. If the gauge port size matches the outlet size, no port size designator is necessary. To order gauge port sizes that do not match the outlet size, add the designator according to the Gauge Port Order diagram on page 8.

Example: LNG6V-8PM-8PF-4PF-4PF-316 for a 1/2 in. female NPT outlet with 1/4 in. female NPT ports.

LP Series Product Design

LP Series Rising Plug valves are used as isolation and gauge valves in oil & gas exploration and refining, chemical and many other applications. LPG Series gauge valves are designed to allow mounting, replacement and calibration of pressure gauges, pressure transmitters, and other instruments and equipment in applications having pressures up to 6000 psig (413 bar), temperatures from -65 to 600°F (-53 to 315°C), high vibration, and frequent cycling. LP Series valve's straight, roddable flow path make them suitable for applications having "dirty", slurries or viscous fluids.

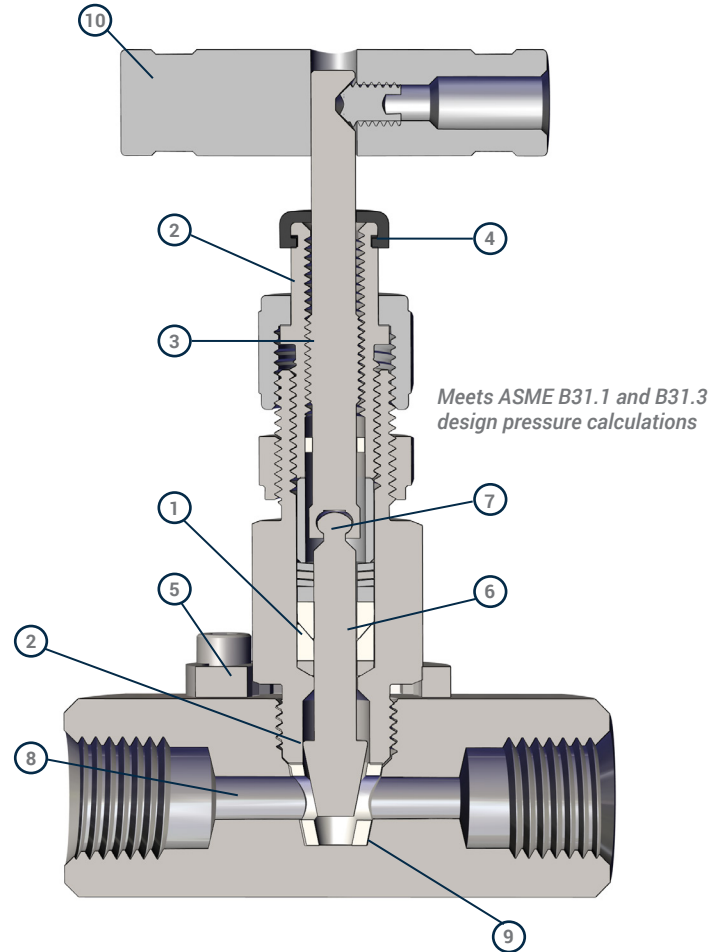

- 1 LIVE LOADED CHEVRON PACKING**
- Reduces need for packing adjustments
 - Compensates for wear
 - Compensates for pressure and temperature changes
 - Packing support prevents extrusion of the packing
 - Easy actuation with positive shutoff
 - Stem will not back out in high-vibration applications
 - PEEK packing is available for high temp. applications

- 2 BACK SEATING STEM ALLOWS INLINE PACKING ADJUSTMENT**
- Easy access to packing bolt – nothing to disassemble
 - Allows in line packing adjustment in pressurized system
 - Isolates the packing when the valve is in the fully open position
 - Makes in-line packing adjustment safer

- 3 HARDENED NON-WETTED STEM THREADS**
- Hardened 17-4 PH stainless steel
 - High cycle life
 - Retains lubricants for easy operation and longer cycle life

- 4 DUST CAP**
- Prevents contamination of the stem threads from the environment

- 5 BONNET LOCK PLATE**
- Locks bonnet in place to prevent accidental disassemble
 - Superior to pin-type retainers

- 6 NON-ROTATING LOWER STEM**
- Prevents damage to the seat and stem tip caused by rotation for repetitive leak-tight sealing even in severe environments
 - Reduces packing maintenance because the stem does not rotate within the packing
 - Chrome-plated, strain-hardened 316 SS

- 7 NON-WETTED STEM PIVOT INTERLOCK**
- Prevents system media from infiltrating and seizing up the stem joint

- 8 STRAIGHT FLOW PATH**
- High Flow
 - Roddable

- 9 REPLACEABLE SEAT**
- Three material choices (Acetal/PFA/PEEK)

- 10 DURABLE STAINLESS STEEL HANDLE**

Materials of Construction

ID	Component	316 SS	Alloy 400
1	Handle Screw	316 SS/A276	
2	T-Bar Handle	303/A582	
3	Dust Cap	NBR/D2000	
4	Packing Nut	316 SS/A276	
5	Packing Bolt	316 SS/A276	
6	Stem Guide	PEEK/D1710	
7	Upper Stem	17-4PH/A564	
8	Packing Spacer	316 SS/A276	
9	Packing Springs (3)	301/A666	
10	Packing Washer	316 SS/A276	
11*	Upper Packing	PTFE/D1710, PEEK ¹	
12*	Lower Packing	PTFE/D1710, PEEK ¹	
13*	Packing Support	316 SS/A276	Alloy 405/B164
14*	Lower Stem	Chrome-plated 316 SS/A276	Chrome-plated Alloy 405/B164
15	Panel Nut (Optional)	316 SS/A276	
16*	Bonnet	316 SS/A276	Alloy 405/B164
17*	Seat Pin	316 SS/A276	Alloy 405/B164
18*	Seat	Acetal, PFA, PEEK	
19	Socket Screw	316 SS/A276	
20	Bonnet Lock	316 SS/A276	
21*	Body	316 SS/A479	Alloy 400/B164
	Packing Lubricant	Fluorocarbon-based lubricant	
	Thread Lubricant	Fluorocarbon-based lubricant with Tungsten Disulfide	

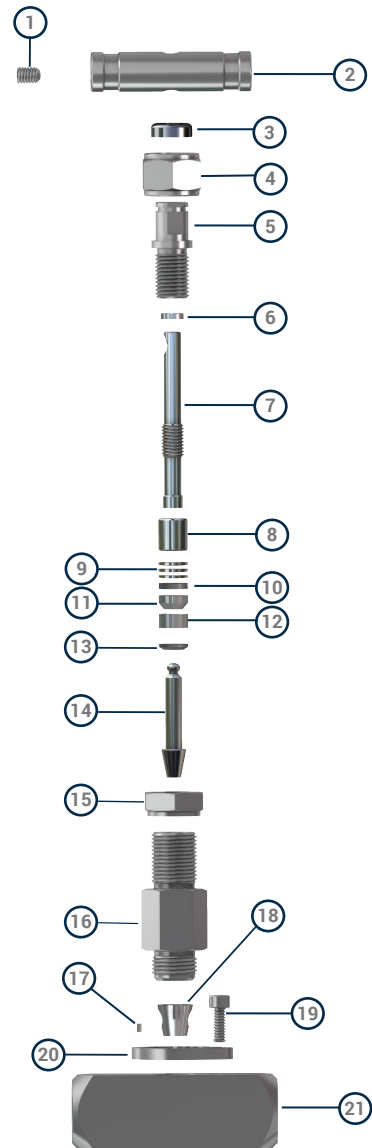

*Wetted components

¹ PEEK packing is standard with PEEK seats.

Temperature-Pressure

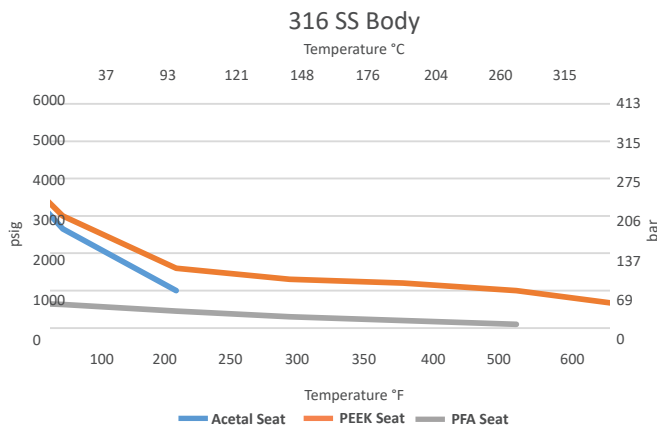

Ordering Information

Ordering LP Series gauge valves requires the following steps:

- 1 Locate the part number with the required body size and end connection type(s) and size(s).
Example: **LPG6-4PF**
- 2 Add the required Seat Material Designator. Use D for Acetal, T for PFA or P for PEEK.
Example LPG6**D**-4PF
- 3 Add the Body Material Designator. Use -316 for 316 Stainless Steel, or -M for Alloy 400.
Example: LPG6D-4PF-**316**
- 4 Add designators for other options in alphabetical order (see pages 14-15). Example: LPG6-4PF-316-**SG2**

NOTE: For configurations that are not in the catalog, see the Special Order instructions on page 15.

LP Series

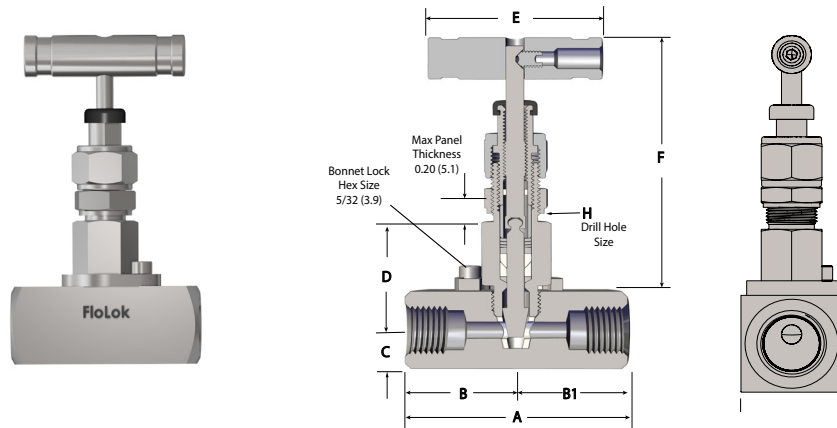

Basic Part Numbers and Dimensions

End Connection			Basic Part Number	Orifice in. (mm)	CV	DIMENSIONS in. (mm)								
Type	Inlet Size	Outlet Size				A	B	B1	C	D	E	F	G	H
Female NPT	1/4	1/4	LP6-4PF	0.187 (3.96)	0.85	2.24 (56.9)	1.12 (28.5)	1.12 (28.5)	0.44 (11.2)	1.35 (34.3)	2.50 (63.5)	3.85 (97.8)	1.10 ¹ (27.9)	11/16 or 23/32
	1/2	1/2	LP6-8PF	0.250 (6.35)	1.65	2.66 (67.6)	1.33 (33.8)	1.33 (33.8)	0.56 (14.2)	1.46 (37.1)	2.50 (63.5)	3.95 (100.3)	1.13 (28.6)	11/16 or 23/32
Male to Female NPT	1/4	1/4	LP6-4PM-4PF	0.187 (3.96)	0.85	2.9 (73.7)	1.78 (45.2)	1.12 (28.5)	0.44 (11.2)	1.35 (34.3)	2.50 (63.5)	3.85 (97.8)	1.10 ¹ (27.9)	11/16 or 23/32
	1/2	1/4	LP6-8PM-4PF	0.187 (3.96)	0.85	3.07 (76.5)	1.50 (38.1)	1.51 (38.4)	0.44 (11.2)	1.35 (34.3)	2.50 (63.5)	3.85 (97.8)	1.10 ¹ (27.9)	11/16 or 23/32
	1/2	1/2	LP6-8PM-8PF	0.250 (6.35)	1.65	3.48 (88.6)	2.15 (54.6)	1.33 (33.8)	0.56 (14.2)	1.46 (37.1)	2.50 (63.5)	3.95 (100.3)	1.13 (28.6)	11/16 or 23/32
	3/4	1/2	LP6-12PM-8PF	0.250 (6.35)	1.65	3.50 (88.9)	1.75 (44.5)	1.75 (44.5)	0.56 (14.2)	1.46 (37.1)	2.50 (63.5)	3.95 (100.3)	1.13 (28.6)	11/16 or 23/32

¹ Bonnet lock ring is wider than the body. Actual body width is 0.88 in (22.4 mm).

² To order other gauge port sizes, see the Special Orders guide on page 15.

³ Valve dimensions are subject to change.

⁴ Other end connection types are available. See the Special Orders guide on page 15.

LPG Series

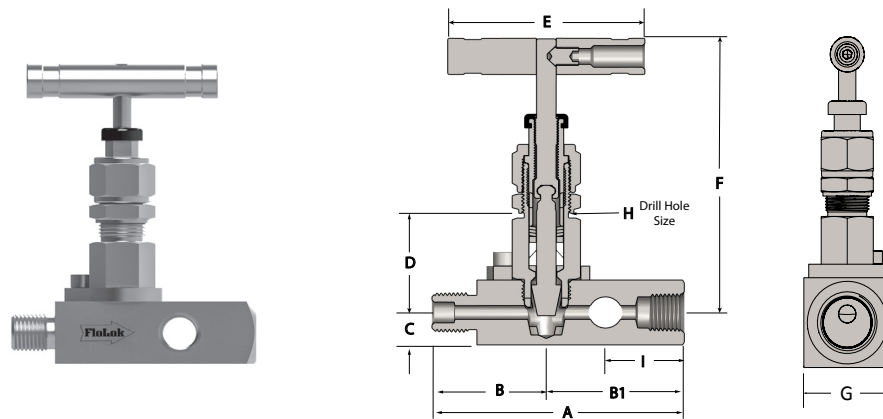

Basic Part Numbers and Dimensions cont.

End Connection			Gauge Port Sizes ²	Basic Part Number	Orifice in. (mm)	Cv	Dimensions in. (mm)									
Type	Inlet Size	Outlet Size					A	B	B1	C	D	E	F	G	H	I
Rising Plug Gauge Valves																
Female NPT	1/4	1/4	1/4	LPG6-4PF	0.187 (3.96)	0.85	2.87 (72.9)	1.12 (28.5)	1.75 (44.5)	0.44 (11.2)	1.35 (34.3)	2.50 (63.5)	3.85 (97.8)	1.10 ¹ (27.9)	11/16 or 23/32	1.00 (25.4)
	1/2	1/2	1/2	LPG6-8PF	0.250 (6.35)	1.65	3.58 (90.9)	1.48 (37.6)	2.10 (51.1)	0.63 (16.8)	1.46 (37.1)	2.50 (63.5)	3.95 (100.3)	1.25 (31.8)	11/16 or 23/32	1.20 (30.5)
	1/2	1/2	1/4	LPG6-8PF-8PF-4PF	0.250 (6.35)	1.65	3.58 (90.9)	1.48 (37.6)	2.10 (51.1)	0.56 (14.2)	1.46 (37.1)	2.50 (63.5)	3.95 (100.3)	1.13 (28.6)	11/16 or 23/32	1.20 (30.5)
Male to Female NPT	1/2	1/4	1/4	LPG6-8PM-4PF	0.187 (3.96)	0.85	3.50 (88.9)	1.75 (44.4)	1.75 (44.5)	0.44 (11.2)	1.35 (34.3)	2.50 (63.5)	3.85 (97.8)	1.10 ¹ (27.9)	11/16 or 23/32	1.00 (25.4)
	1/2	1/2	1/2	LPG6-8PM-8PF	0.250 (6.35)	1.65	4.41 (112.0)	2.16 (54.9)	2.25 (57.2)	0.63 (16.8)	1.46 (37.1)	2.50 (63.5)	3.95 (100.3)	1.25 (31.8)	11/16 or 23/32	1.35 (34.3)
Rising Plug Gauge Valves with Extended Inlets																
Male to Female NPT	1/2	1/4	1/4	LPG6-8PML-4PF	0.187 (3.96)	0.85	4.87 (123.7)	3.12 (79.2)	1.75 (44.5)	0.44 (11.2)	1.35 (34.3)	2.50 (63.5)	3.85 (97.8)	1.25 (31.8)	11/16 or 23/32	1.00 (25.4)
	1/2	1/4	1/4	LPG6-8PML4-4PF	0.187 (3.96)	0.85	6.87 (174.5)	5.12 (130.0)	1.75 (44.5)	0.44 (11.2)	1.35 (34.3)	2.50 (63.5)	3.85 (97.8)	1.25 (31.8)	11/16 or 23/32	1.00 (25.4)
	1/2	1/4	1/4	LPG6-8PML6-4PF	0.187 (3.96)	0.85	8.87 (225.3)	7.12 (180.8)	1.75 (44.5)	0.44 (11.2)	1.35 (34.3)	2.50 (63.5)	3.85 (97.8)	1.25 (31.8)	11/16 or 23/32	1.00 (25.4)
	1/2	1/2	1/2	LPG6-8PML-8PF	0.250 (6.35)	1.65	5.58 (141.7)	3.33 (84.6)	2.25 (57.2)	0.63 (16.8)	1.46 (37.1)	2.50 (63.5)	3.95 (100.3)	1.25 (31.8)	11/16 or 23/32	1.35 (34.3)
	1/2	1/2	1/2	LPG6-8PML4-8PF	0.250 (6.35)	1.65	7.58 (192.5)	5.33 (135.4)	2.25 (57.2)	0.63 (16.8)	1.46 (37.1)	2.50 (63.5)	3.95 (100.3)	1.25 (31.8)	11/16 or 23/32	1.35 (34.3)
	1/2	1/2	1/2	LPG6-8PML6-8PF	0.250 (6.35)	1.65	9.58 (243.3)	7.33 (186.2)	2.25 (57.2)	0.63 (16.8)	1.46 (37.1)	2.50 (63.5)	3.95 (100.3)	1.25 (31.8)	11/16 or 23/32	1.35 (34.3)
	3/4	1/2	1/2	LPG6-12PML-8PF	0.250 (6.35)	1.65	5.58 (141.7)	3.33 (84.6)	2.25 (57.2)	0.56 (14.2)	1.46 (37.1)	2.50 (63.5)	3.95 (100.3)	1.25 (31.8)	11/16 or 23/32	1.35 (34.3)
	3/4	1/2	1/2	LPG6-12PML4-8PF	0.250 (6.35)	1.65	7.58 (192.5)	5.33 (135.4)	2.25 (57.2)	0.56 (14.2)	1.46 (37.1)	2.50 (63.5)	3.95 (100.3)	1.25 (31.8)	11/16 or 23/32	1.35 (34.3)
	3/4	1/2	1/2	LPG6-12PML6-8PF	0.250 (6.35)	1.65	9.58 (243.3)	7.33 (186.2)	2.25 (57.2)	0.56 (14.2)	1.46 (37.1)	2.50 (63.5)	3.95 (100.3)	1.25 (31.8)	11/16 or 23/32	1.35 (34.3)

¹ Bonnet lock ring is wider than the body. Actual body with is 0.88 in (22.4 mm).

² To order other gauge port sizes, see the Special Orders guide on page 15.

³ Valve dimensions are subject to change.

⁴ Other end connection types are available. See the Special Orders guide on page 15.

Options and Accessories

Seat Material

Select the seat material designator from the table below then insert it into the basic part number following the series designator.

Examples: *LP6D-8PF-316 Acetal Seat*
LP6P-8PF-316 PEEK Seat

Stem Type	Designator
Acetal	D
PFA	T
PEEK	P

Body Material

Select the valve body material required and add the designator to the valve basic part number after the end connection designators.

Example: *LP6-8PF-M*

Material	Designator
316 Stainless Steel	-316
Alloy 400	-M

Panel Mounting

To order panel nuts to mount LP Series valves on bulkheads, panels and cabinets use part number L6-6A-316.

Bleed Valves & Plugs

SSP BV Series bleed valves and TruFit® plugs can be ordered installed or shipped loose with gauge valves. To order, see the Bleed Valve and Plugs options on page 8.

Sour Gas Service

Selecting valves for sour gas applications requires the consideration of several factors including the temperature, pH, partial pressure of H₂S, and whether the application is above or below ground. SSP offers four configurations to meet the requirements in ANSI/NACE MR0175/ISO 15156-3 and NACE MR0103/ISO 19745. To order valves for your sour gas applications, add the designator below to the part number. Example: *LPG6P-8PM-8PF-316-SG2*

Designator	Wetted Part ¹	Non-Wetted	Body
SG1	Annealed 316 SS except body ²	316 SS	316 SS
SG2	Annealed 316 SS	316 SS	316 SS
SG3	Alloy 400/UNS S20910	316 SS	Alloy 400
SG4	Alloy 400/UNS S20910	Alloy 400	Alloy 400

¹Springs or other components may require other materials for functionality.

²Compression fittings and valve bodies with compression fitting ports are exempt from lower hardness requirements per ANSI/NACE MR0175/ISO 15156 and NACE MR0103/ISO 19745.

Replacement Handles and Dust Caps

To order replacement handles and dust caps, use the part number from the table below.

Valve Series	T-bar	Dust Cap
LP6	L6-7A-303	L6-3C-NBR

Maintenance Kits

Bonnet kits are preassembled and ready to install in the valve body. Seat kits include the seat and seat pin used to align and secure the seat in the valve body. To order bonnet rebuild kits, find the designator for the packing material required then add the body material designator to the part number. Example: *LP6-RK-TFE-316*.

To order seat kits, select the designator for the seat material and orifice size of the valve. The orifice size can be found by looking up the part number of the valve in the Basic Part Numbers and Dimensions table.

Example: Valve part number *LPG6D-8PM-4PF-316* will require the **LP6-RK-187-D** seat kit.

Type	Packing Material	Orifice	Part Number
Bonnet	PTFE	All	LP6-RK-TFE
	PEEK		LP6-RK-PK
Type	Seat Material	Orifice	Part Number
Seat	PFA	0.187	LP6-RK-187-TFE
	Acetal		LP6-RK-187-D
	PEEK		LP6-RK-187-PK
	PFA	0.250	LP6-RK-250-TFE
	Acetal		LP6-RK-250-D
	PEEK		LP6-RK-250-PK

Special Cleaning

LP Series valves are available cleaned in compliance with ASTM G93 Level C and CGA G-4.1, *Cleaning Methods and Cleanliness Levels for Material and Equipment Used in Oxygen-Enriched Environments*. To specify, add -XP98 to the part number.

Example: *LP6D-8PF-316-XP98*

For more information about other types of special cleaning, please contact your local SSP distributor or SSP Customer Service.

Special Orders

The Basic Part Numbers and Dimensions Tables contain only the most popular valve configurations; many other configurations are available. Use the chart below to build part numbers for quotation purposes.

Series/Size	Seat	Inlet	Outlet	Ports	Body	Options
A	B	C	D	E	F	G
LP6	D	-8PM	-8PF	-4PF -4PF	-316	-SG1

- A SERIES / SIZE**
LP6 Rising Plug
LPG6 Gauge
- B SEAT MATERIAL**
D Acetal
T PFA
P PEEK
- F BODY MATERIAL**
-316 316 SS
-M Alloy 400

C D E
INLET² + OUTLET² / PORT³ TYPES & SIZES

End Connections	Fractional Sizes:
*PF Female NPT	2 1/8 in.
*PML Male NPT Extended Inlet	4 1/4 in.
*PM Male NPT	6 3/8 in.
*SW Tube Socket Weld	8 1/2 in.
*PSW Pipe Socket Weld	12 3/4 in.

* To designate a connection size and type, replace the * with the fractional size designator. Example: 4PML

G OPTIONS¹

SOUR GAS	BLEED VALVES AND PLUGS	SPECIAL CLEANING
-SG1 See page 14 for materials construction	See ordering Bleed Valves and Plugs instructions on page 8.	-XP98 Oxygen compatible lubricant, per ASTM G93, Level C and CGA G-4.1
-SG2		
-SG3		
-SG4		

¹ Add options designators to the end of the Base Part Number in alphabetical order.
² If both ends match, use only one end connection designator. Example: LPG6D-8PF-316
 If the ends do not match, designate the inlet then the outlet. Example: LP6GD-8PM-8PF-316
³ Gauge valve ports are 1/4 or 1/2 in. female NPT only. If the gauge port size matches the outlet size, no designator is necessary. To order gauge port sizes that do not match the outlet size add the designator according to the diagram on page 8.
 Example: LPG6D-8PM-8PF-4PF-4PF-316 for 1/2 in. female NPT outlet with 1/4 in. female NPT gauge ports.
 Bleed valve vent ports are 1/4 in. female NPT only.

⚠ Important Information

IMPROPER SELECTION OR IMPROPER USE OF THE PRODUCTS DESCRIBED HEREIN OR RELATED ITEMS CAN CAUSE PERSONAL INJURY AND PROPERTY DAMAGE. It is the sole responsibility of the system designers and users to properly select and use products for their specific applications. This document has been provided to users with technical expertise as a reference for further investigation to determine specific product needs relative to their design requirements.

- ⚠ Packing must be adjusted for applications with working pressure higher than 1000 psig (69 bar) or if the valves have been exposed to high or low temperatures prior to installation. Instructions for packing adjustments are included with each valve.
- Valves that have not been actuated for extended periods of time may require greater actuation torque.

Testing

All valves are factory tested with Nitrogen to 1000 psig (69 bar) at 70°F (20°C). **Note: Packing adjustments may be required for applications with higher pressures and/or higher or lower process or environmental temperatures.**

Warranty

SSP valves are backed by the SSP Lifetime Limited Warranty. This warranty is available from your local distributor or at www.mySSP.com.

SSP

Founded 1926

Privately owned, third generation business

Modern single-site vertically integrated manufacturing facility

DFARS-compliant raw material

ISO 9001 quality management system

Limited Lifetime Warranty



*The Only
100% American Made
Instrument Valves & Fittings*

8250 Boyle Parkway • Twinsburg, OH 44087
330-425-4250 • www.mySSP.com

©2020 SSP Fittings Corp. All rights reserved.

GVPC-20A