

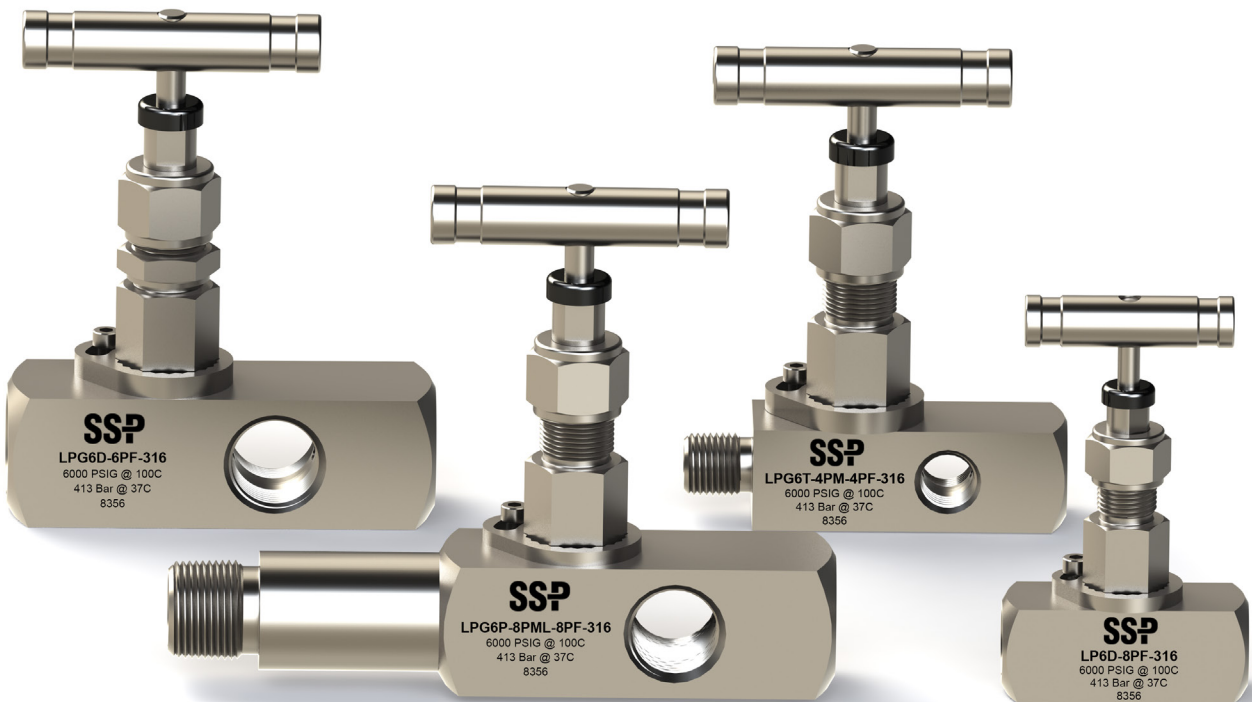

Rising Plug and Gauge Valves



LP Series

- ✓ Pressure: Up to 6000 psig (413 bar)
- ✓ Temperature: -65 to 600° F (-53 to 315° C)
- ✓ Locked bonnet eliminates accidental disassembly of the bonnet
- ✓ Live-loaded packing reduces the need for packing adjustments





At SSP we are proud to be an American success story and each day our products are specified and used across America and the rest of the world.

100% of our products are made in the USA and are manufactured in our 165,000 sq. ft. facility based near Cleveland, Ohio. Throughout our manufacturing we use the latest technology and quality control procedures.

Our facility is the largest single-site operation in the entire industry and includes tool and die design, production, custom closed-die forging, machining, finishing operations, assembly and rigorous product testing.

We also carefully select each of our supply chain partners, many of whom are local using the latest in Kaizen and Six Sigma methodology.

TABLE of CONTENTS

Introduction	3	Part Numbers and Dimensions	
Product Design	4	Rising Plug	7
Materials of Construction	5	Gauge	8
Temperature and Pressure Ratings	5	Options & Accessories.....	9
Ordering Information	6	Special Order Instructions	10
		Safety, Testing, Warranty	10

LP Series Rising Plug and Gauge Valves

Better Rising Plug and Gauge Valves

LP Series rising plug and gauge valves use a unique combination of features that can reduce maintenance time and cost, improve safety and increase the reliability of instruments in your systems.

Locked Bonnet Design for Greater Safety

The LP Series valve takes the best aspects of union bonnet and screwed bonnet designs to provide safer and more reliable service. LP Series' bonnets incorporate the stem, packing nut, packing bolt and packing into a single assembly. The bonnet is screwed into the valve body, then locked in place with a lock ring. This design prevents accidental disassembly from over-rotating the handle past fully open or from loosening due to vibration. The back seating plug allows inline packing adjustments to be made more safely.

Live loaded Chevron Packing for Greater Reliability

The tighter your system, the better your data. LP Series valves are designed with live loaded packing that provides a dynamic leak-tight stem seal, which compensates for changes in pressure, temperature and packing wear.

Severe Service Construction

LP Series rising plug and gauge valves are built for demanding conditions. In addition to the bonnet construction, LP Series valves feature a non-rotating lower stem that prevents seat damage and reduces wear to the seat and packing caused by rotational damage. The threaded upper stem and stem pivot are located above the packing to prevent system media from attacking the threads or from washing away thread lubricants. A dust cap prevents dust and other environmental elements from contaminating the threads.

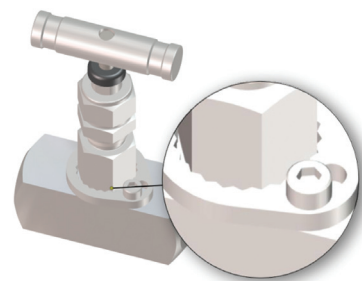

LP Series Locked Bonnet Design

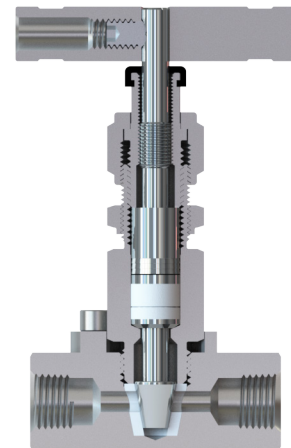

Product Design

Meets ASME B31.1 and B31.3 design pressure calculations

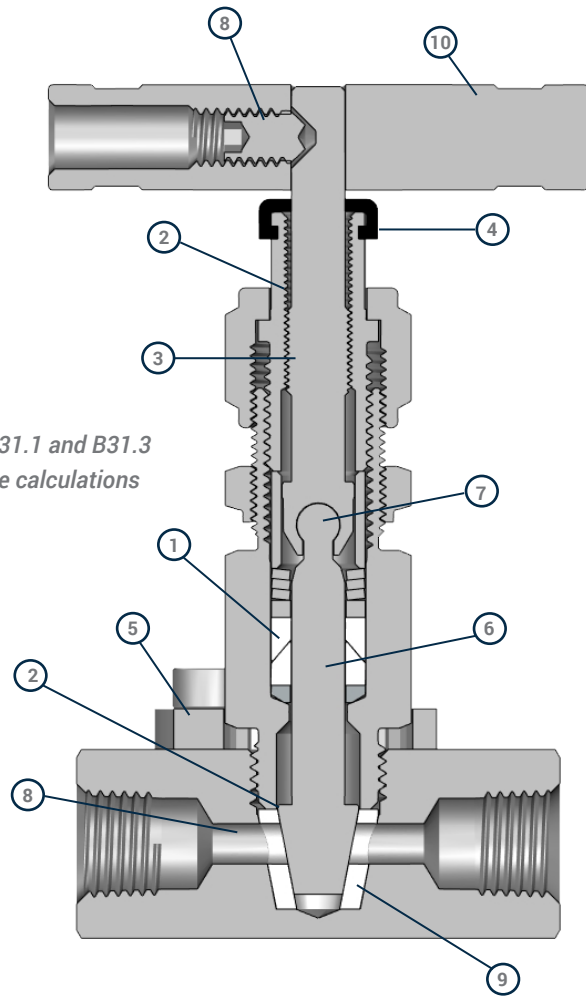

1 LIVE LOADED CHEVRON PACKING

- Reduces need for packing adjustments
- Compensates for wear
- Compensates for pressure and temperature changes
- Packing support prevents extrusion of the packing
- Easy actuation with positive shutoff
- Stem will not back out in high-vibration applications

2 BACK SEATING STEM ALLOWS FOR INLINE PACKING ADJUSTMENT

- Isolates the packing when the valve is in the fully open position
- Makes packing adjustment safer

3 HARDENED NON-WETTED STEM THREADS

- Hardened 17-4 PH stainless steel
- High cycle life
- Retains lubricants for easy operation and longer cycle life

4 DUST CAP

- Prevents contamination of the stem threads from the environment

5 BONNET LOCK PLATE

- Locks bonnet in place to prevent accidental disassembly

6 NON-ROTATING LOWER STEM

- Prevents damage to the seat and stem tip caused by rotational damage, for repetitive leak-tight sealing even in severe environments
- Reduces packing maintenance because the stem does not rotate within the packing
- Chrome-plated, strain-hardened 316 SS

7 NON-WETTED STEM PIVOT INTERLOCK

- Prevents system media from infiltrating and seizing up the stem joint

8 STRAIGHT FLOW PATH

- High Flow
- Roddable

9 REPLACEABLE SEAT

- Three material choices (Acetal/PFA/PEEK)

10 DURABLE STAINLESS STEEL HANDLE

Materials of Construction

ID	COMPONENT	MATERIAL	SPECIFICATION
1	Handle Screw	316 SS	A276
2	T-Bar Handle	303	A582
3	Dust Cap	NBR	D2000
4	Packing Nut	316 SS	A276
5	Packing Bolt	316 SS	A276
6	Upper Stem	17-4PH	A564
7	Packing Spacer	316 SS	A276
8	Packing Springs	301	A666
9	Packing Washer	316 SS	A276
10*	Upper Packing	PTFE / PEEK	D1710
11*	Lower Packing	PTFE / PEEK	D1710
12*	Packing Support	316 SS	A176
13*	Lower Stem	316 SS / Alloy 405	A276
14	Panel Nut (Optional)	316 SS	A176
15*	Bonnet	316 SS / Alloy 400	A479
16*	Seat Pin	316 SS	A276
17*	Seat	Acetal / PFA / PEEK	
18	Set Screw	316 SS	A276
19	Bonnet Lock	316 SS	A276
20*	Body	316 SS / Alloy 400	A479
	Thread Lubricant	Christo-Lube MCG 130	
	Packing Lubricant	Christo-Lube MCG 111	

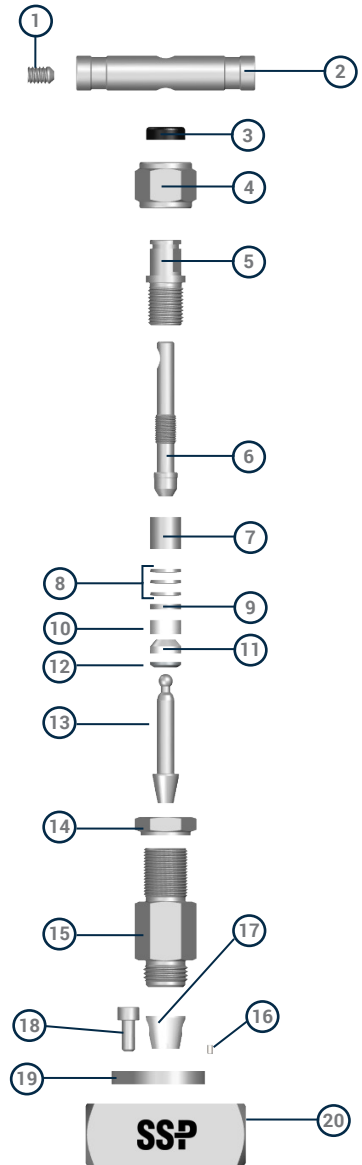

*Wetted components

Temperature Pressure Tables

SERIES	SS 316			ALLOY 400		
	Acetal	PEEK	PFA	Acetal	PEEK	PFA
Seat Material	Acetal	PEEK	PFA	Acetal	PEEK	PFA
Temperature	Working Pressure - psig (bar)					
-65 to 100°F (-53 to 37°C)	6000 (413)	6000 (413)	750 (51.6)	5000 (344)	5000 (344)	750 (51.6)
200°F (93°C)	2650 (182)	3000 (206)	625 (43.0)	2650 (182)	3000 (206)	625 (43.0)
250°F (121°C)	1000 (68.9)	1600 (110)	450 (31.0)	1000 (68.9)	1600 (110)	450 (31.0)
300°F (148°C)	-	1300 (89.5)	300 (20.6)	-	1300 (89.5)	300 (20.6)
350°F (176°C)	-	1200 (82.6)	200 (13.7)	-	1200 (82.6)	200 (13.7)
400°F (204°C)	-	1000 (68.9)	100 (6.8)	-	1000 (68.9)	100 (6.8)
500°F (260°C)	-	600 (41.3)	-	-	600 (41.3)	-
600°F (315°C)	-	200 (13.7)	-	-	-	-

Ordering Information

Ordering LP Series valves requires the following steps:

- 1 *Locate the part number with the required body size, orifice size, and end connection type(s) and size(s). (see pages 07-08)*

*Example: **LP6-4PF** Rising Plug Valve*

*Example: **LPG6-4PF** Gauge Valve*

- 2 *Add the required Seat Material Designator (see page 09). Example LP6**D**-4PF*

- 3 *Add the Body Material Designator (see page 09). Example: LP6D-4PF-**316***

- 4 *Add designators for Options (see page 09).*

NOTE: For configurations that are not in the catalog, see the Special Order instructions on page 10.

Basic Part Numbers and Dimensions

Rising Plug Valves

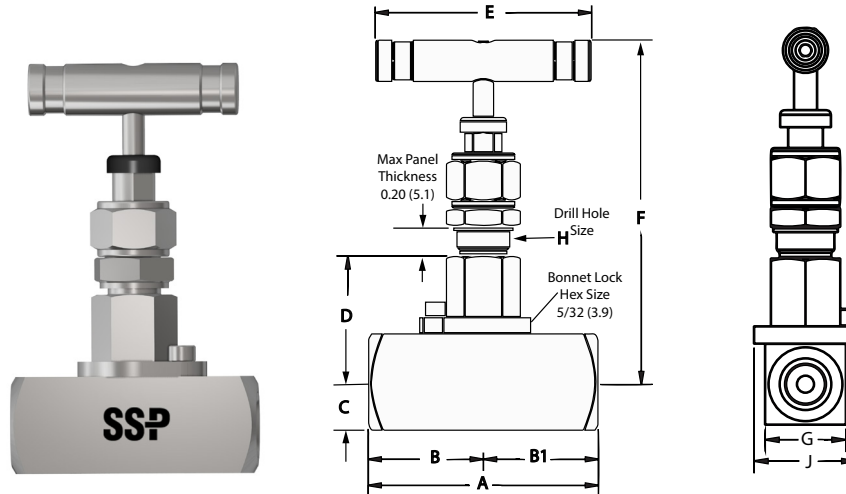

End Connection			Basic Part Number	Orifice in. (mm)	CV	DIMENSIONS in. (mm)									
Type	Inlet Size	Outlet Size				A	B	B1	C	D	E	F	G	H	J
Female NPT	1/4	1/4	LP6-4PF	0.187 (3.96)	0.85	2.24 (56.9)	1.12 (28.5)	1.12 (28.5)	0.44 (11.2)	1.35 (34.3)	2.50 (63.5)	3.85 (97.8)	0.88 (22.2)	11/16 or 23/32	1.10 (27.9) ¹
	1/2	1/2	LP6-8PF	0.250 (6.35)	1.65	2.66 (67.6)	1.33 (33.8)	1.33 (33.8)	0.56 (14.2)	1.46 (37.1)	2.50 (63.5)	3.95 (100.3)	1.13 (28.6)	11/16 or 23/32	1.10 (27.9)
Male to Female NPT	1/4	1/4	LP6-4PM-4PF	0.187 (3.96)	0.85	2.9 (73.7)	1.78 (45.2)	1.12 (28.5)	0.44 (11.2)	1.35 (34.3)	2.50 (63.5)	3.85 (97.8)	0.88 (22.2)	11/16 or 23/32	1.10 (27.9) ¹
	1/2	1/4	LP6-8PM-4PF	0.187 (3.96)	0.85	3.07 (76.5)	1.50 (38.1)	1.51 (38.4)	0.44 (11.2)	1.35 (34.3)	2.50 (63.5)	3.85 (97.8)	0.88 (22.2)	11/16 or 23/32	1.10 (27.9) ¹
	1/2	1/2	LP6-8PM-8PF	0.250 (6.35)	1.65	3.48 (88.6)	2.15 (54.6)	1.33 (33.8)	0.56 (14.2)	1.46 (37.1)	2.50 (63.5)	3.95 (100.3)	1.13 (28.6)	11/16 or 23/32	1.10 (27.9)
	3/4	1/2	LP6-12PM-8PF	0.250 (6.35)	1.65	3.50 (88.9)	1.75 (44.5)	1.75 (44.5)	0.56 (14.2)	1.46 (37.1)	2.50 (63.5)	3.95 (100.3)	1.13 (28.6)	11/16 or 23/32	1.10 (27.9)

¹ Bonnet lock ring is wider than the body

Basic Part Numbers and Dimensions

Rising Plug Gauge Valves

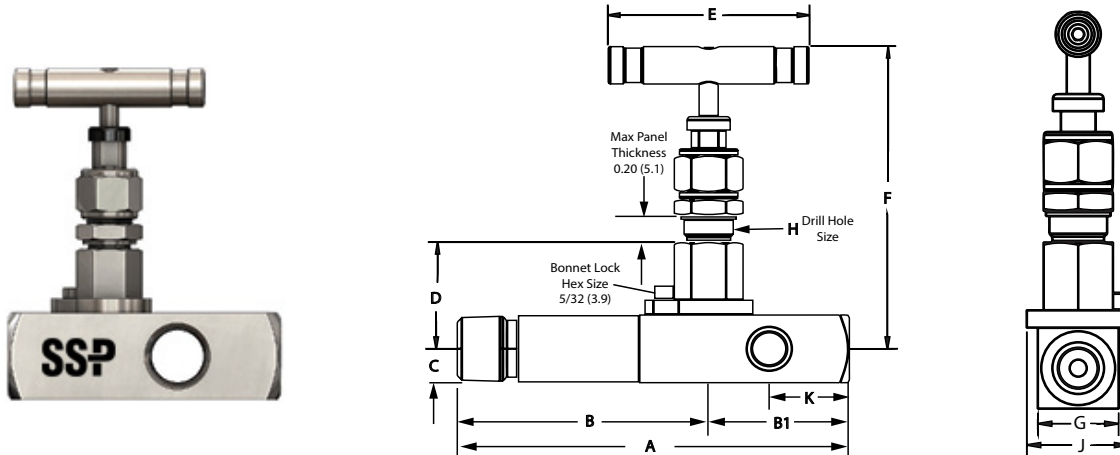

End Connection			Gauge Port Sizes ²	Basic Part Number	Orifice in. (mm)	CV	Dimensions in. (mm) ⁴										
Type ⁵	Inlet Size	Outlet Size					A ³	B ³	B1	C	D	E	F	G	H	J	K
Female NPT	1/4	1/4	1/4	LPG6-4PF	0.187 (3.96)	0.85	2.87 (72.9)	1.12 (28.5)	1.75 (44.5)	0.44 (11.2)	1.35 (34.3)	2.50 (63.5)	3.85 (97.8)	0.88 (22.2)	11/16 or 23/32	1.10 (27.9) ¹	1.00 (25.4)
	1/2	1/2	1/2	LPG6-8PF	0.250 (6.35)	1.65	3.58 (90.9)	1.48 (37.6)	2.10 (51.1)	0.63 (16.8)	1.46 (37.1)	2.50 (63.5)	3.95 (100.3)	1.25 (31.8)	11/16 or 23/32	1.10 (27.9)	1.20 (30.5)
	1/2	1/2	1/4	LPG6-8PF-8PF-4PF	0.250 (6.35)	1.65	3.58 (90.9)	1.48 (37.6)	2.10 (51.1)	0.56 (14.2)	1.46 (37.1)	2.50 (63.5)	3.95 (100.3)	1.13 (28.6)	11/16 or 23/32	1.10 (27.9)	1.20 (30.5)
Male to Female NPT	1/2	1/4	1/4	LPG6-8PM-4PF	0.187 (3.96)	0.85	3.50 (88.9)	1.75 (44.4)	1.75 (44.5)	0.44 (11.2)	1.35 (34.3)	2.50 (63.5)	3.85 (97.8)	0.88 (22.2)	11/16 or 23/32	1.10 (27.9) ¹	1.00 (25.4)
	1/2	1/2	1/2	LPG6-8PM-8PF	0.250 (6.35)	1.65	4.41 (112.0)	2.16 (54.9)	2.25 (57.2)	0.63 (16.8)	1.46 (37.1)	2.50 (63.5)	3.95 (100.3)	1.25 (31.8)	11/16 or 23/32	1.10 (27.9)	1.20 (30.5)

¹ Bonnet lock ring is wider than the body

² To order other gauge port sizes, see instructions on page 10

³ LNG Series gauge valves with male NPT and pipe socket weld end connections are available with 2, 4 and 6 inch lagging for use with insulated pipe. To order extended inlets, see the instructions on page xxx. To calculate the dimensions of a valve with lagging, add the extension length to the A and B dimensions in the chart above.

⁴ Valve dimensions are subject to change.

⁵ Other end connection types are available. Please see the Special Orders guide on page xxx.

Options & Accessories

Lagging (Extended Inlet)

To specify lagging, or and extended inlet find the required extension length in the table below, then insert the designator after the inlet type in the part number. *Example: LNG8V-8PML4-8PF-316*

Designator	Add to A & B dimensions in. (mm)
L	2.26 (57.4)
L4	4 (101.6)
L6	6 (152.4)

Seat Material

Select the seat material designator from the table below then insert it into the basic part number following the series designator.

*Examples: LP6D-8PF-316 - Acetal Seat
LP6P-8PF-316 - PEEK Seat*

STEM TYPE	DESIGNATOR
Acetal	D
PFA	T
PEEK	P

Body Material

Select the valve body material required and add the designator to the valve basic part number after the end connection designators.

Example: LP6-8PF-M

MATERIAL	DESIGNATOR
316 Stainless Steel	-316
Alloy 400	-M

Bleed & Purge Valves

SSP offers bleed and purge valves for installation in LP Series Gauge Valves. For more information, go to www.mySSP.com or contact your authorized SSP distributor.



Rebuild Kits

Seat and bonnet rebuild kits are available. Bonnet kits are preassembled and ready to install in the valve body. Seat kits include the seat and seat pin used to align and secure the seat in the valve body. To order rebuild kits, contact your authorized SSP distributor or SSP Customer Service.

Replacement Handles and Dust Caps

To order replacement handles and dust caps, use the part number from the table below.

VALVE SERIES	T-BAR	DUST CAP
LP6	L6-7A-303	L6-3C-NBR

Sour Gas Service

LP Series rising plug valves constructed with materials selected in accordance with NACE MR0175/ ISO 15156 are available for sour gas service.

To order add -SG to the part number.

Example: LP6D-4PF-4PM-316-SG

Panel Mounting

To order panel nuts to mount LP Series valves on bulkheads, panels and cabinets use part number L6-6A-316.

Special Cleaning

LP Series valves are available with ASTM G93 Level C and CGA G-4.1 compliant cleaning. To specify special cleaning, add -XP98 to the part number.

Example: LP6D-8PF-316-XP98

For more information about special cleaning, please contact your local SSP distributor or SSP Customer Service.

Special Orders

The Basic Part Numbers and Dimensions tables (pages 7 and 8) contain only the most popular valve configurations; many more are available. If the required valve configuration is not in the Basic Part Numbers and Dimensions tables, use the chart below to build part numbers for quotation purposes.

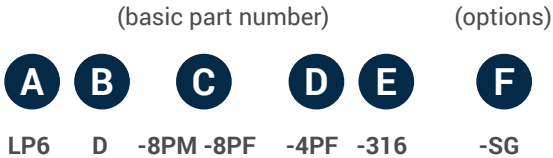

<p>A SERIES / SIZE</p> <p>LP6 Rising Plug LPG6 Gauge</p>	<p>C + D INLET² + OUTLET² / PORT³ SIZE- TYPES</p> <table border="0"> <tr> <td>*PF</td> <td>Female NPT</td> <td>Fractional Sizes:</td> <td></td> </tr> <tr> <td>*PML</td> <td>Male NPT Extended Inlet</td> <td>2</td> <td>1/8 in.</td> </tr> <tr> <td>*PM</td> <td>Male NPT</td> <td>4</td> <td>1/4 in.</td> </tr> <tr> <td>*SW</td> <td>Tube Socket Weld</td> <td>6</td> <td>3/8 in.</td> </tr> <tr> <td>*PSW</td> <td>Pipe Socket Weld</td> <td>8</td> <td>1/2 in.</td> </tr> <tr> <td></td> <td></td> <td>12</td> <td>3/4 in.</td> </tr> <tr> <td></td> <td></td> <td>16</td> <td>1 in.</td> </tr> </table> <p><small>* To designate a connection size and type, replace the "*" with the fractional size designator. Example: 4PML</small></p>	*PF	Female NPT	Fractional Sizes:		*PML	Male NPT Extended Inlet	2	1/8 in.	*PM	Male NPT	4	1/4 in.	*SW	Tube Socket Weld	6	3/8 in.	*PSW	Pipe Socket Weld	8	1/2 in.			12	3/4 in.			16	1 in.
*PF	Female NPT	Fractional Sizes:																											
*PML	Male NPT Extended Inlet	2	1/8 in.																										
*PM	Male NPT	4	1/4 in.																										
*SW	Tube Socket Weld	6	3/8 in.																										
*PSW	Pipe Socket Weld	8	1/2 in.																										
		12	3/4 in.																										
		16	1 in.																										
<p>B SEAT MATERIAL</p> <p>D Acetal T PFA P PEEK</p>	<p>E BODY MATERIAL</p> <p>-316 316 Stainless Steel -M Alloy 400</p>																												
<p>F OPTIONS¹</p> <p>SOUR GAS</p> <p>-SG NACE MR01-75 / ISO 15156</p> <p>SPECIAL CLEANING</p> <p>-XP98 Oxygen compatible lubricant, per ASTM G93, Level C and CGA G-4.1</p>																													

Important Information

! *IMPROPER SELECTION OR IMPROPER USE OF THE PRODUCTS DESCRIBED HEREIN OR RELATED ITEMS CAN CAUSE PERSONAL INJURY AND PROPERTY DAMAGE. It is the sole responsibility of the system designers and users to properly select and use products for their specific applications. This document has been provided to users with technical expertise as a reference for further investigation to determine specific product needs relative to their design requirements.*

! *Packing must be adjusted for applications with working pressure higher than 1000 psig (69 bar) or if the valves have been exposed to high or low temperatures prior to installation. Instructions for packing adjustments are included with each valve.*

¹ Add options designators to the end of the Base Part Number in alphabetical order.
² If both ends match, use only one end connection designator. Example: LP6D-8PF-316
 If the ends do not match, designate the inlet then the outlet. Example: LP6D-8PM-8PF-316
³ Gauge ports are 1/4 or 1/2 in. female NPT only. If the gauge port size matches the outlet size, no designator is necessary. To order gauge port sizes that do not match the outlet size add the designator according to the table diagram below. Example: LP6D-8PM-8PF-4PF-4PF-316 for 1/2 in. female NPT outlet with 1/4 in. female NPT gauge ports.

Valves that have not been actuated for extended periods of time may require greater actuation torque.

Bleed & Purge Valves

Bleed and Purge Valves may be ordered and installed at the factory. To find out more, please contact your distributor or visit www.mySSP.com

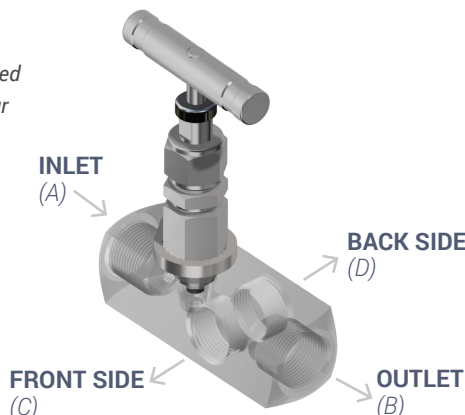

Testing

All LP Series valves are factory tested with Nitrogen to 1000 psig (69 bar) at 70°F (20°C).
Note: Packing adjustments may be required for applications with higher pressures and/or higher or lower process or environmental temperatures.

Warranty

SSP valves are backed by the SSP Limited Lifetime Limited Warranty. This warranty is available from your local distributor or at www.mySSP.com.

More SSP Products



Tube Fittings

Duolok® and Griplok® (two-ferrule) and Unilok® (single-ferrule) tube fittings ensure leak-tight installation when intermixed with Swagelok®, Hoke® Gyrolok®, and Parker® CPI™ fittings, provided they are used in accordance with SSP Fittings' published installation and service recommendations.



Valves

The SSP valve offering includes ball, check, metering, needle, toggle, plug, bleed, and purge valves for pressures up to 10,000 psig.



Quick Connects

SSP offers single-end shutoff, double-end shutoff, and full-flow quick connects for instrumentation and process applications.



Pipe Fittings

TruFit and TruFit 10K pipe fittings are available in a wide range of weld, threaded and flared connections.



Filters

SSP in-line and tee-type filters trap particles to clean sample fluids and protect sensitive process and analytical instrumentation components and equipment.



Tools & Accessories

SSP TurnPro professional hand tools, power tools and installation training make quality tube system installation faster and easier.



SSP

Founded 1926

Privately owned, third generation business

Modern single-site vertically integrated manufacturing facility

DFARS-compliant raw material

ISO 9001 quality management system

Limited Lifetime Warranty



8250 Boyle Parkway • Twinsburg, OH 44087

330-425-4250 • www.mySSP.com