

# SSP

## Proportional Relief Valves



# SSP

## R Series

- ✓ Liquid or Gas Service
- ✓ Set Pressures: 10 to 6000 psig (0.7 to 413 bar)
- ✓ Variety of Seal Materials
- ✓ Variety of End Connections
- ✓ 1/4 and 1/2 in. (6, 8 and 12 mm)

[www.mySSP.com](http://www.mySSP.com)





At SSP, we are proud to be an American manufacturing success story.

**100% of our products are made in America.** All of our manufacturing is performed in our 165,000 sq. ft. facility located near Cleveland, Ohio. Our facility is the largest vertically integrated, single-site operation in the industry. In addition to manufacturing and assembly, we have closed die forging, tool & die design, product engineering and testing operations under the same roof with customer service and management.

**Made in America is good business.** Not only do we make everything in America, we use American suppliers too. Buying American allows us to have better quality control and a more reliable supply chain. We can work more closely within our walls and with our suppliers to improve quality, reduce costs, and shorten lead times, which means faster service and better products for you.

**Support where it counts.** SSP products and services are supported by more than 4000 people and 350 distributor locations around the globe. For a distributor near you, contact SSP Customer Service or visit [www.mySSP.com/distributors](http://www.mySSP.com/distributors).

## TABLE of CONTENTS

Introduction .....	3	Flow Data.....	7
Product Design .....	4	Ordering Information.....	8
Pressure-Temperature .....	5	Options & Accessories .....	9
Set and Resealing Pressure .....	5	Special Order Instructions .....	10
Materials of Construction.....	6	Safety, Warranty .....	10

# R Series Proportional Relief Valves

R Series proportional relief valves are designed to protect pressure sensitive equipment by diverting flow in order to relieve pressure upstream of pressure sensitive equipment such as analyzers and flow meters. They open when the upstream pressure exceeds the closing force exerted by the spring, permitting flow through the valve. Flow through the valve increases and decreases proportionately in response to changes in upstream pressure. Proportional relief valves reseal at a pressure lower than the cracking pressure.

## Specifications

### High-Pressure Valves

- Maximum Working Pressure: 6000 psig (413 bar)
- Set Pressure: 50 to 6000 psig (3.4 to 413 bar)
- Multiple springs for a selection of set pressure ranges improve accuracy and reduce hysteresis
- End Connections:
  - RH3: 1/4 in., 6 mm and 8 mm tube ends  
1/4 in. NPT and BSPT pipe ends
  - RH4: 1/2 in. and 12 mm tube ends  
1/2 in. NPT pipe ends

### Low-Pressure Valves

- Maximum Working Pressure: 300 psig (20.6 bar)
- Set Pressures 10 to 225 psig (0.7 to 15.5 bar)
- One spring for the full set pressure range
- End Connections:
  - RL3: 1/4 in., 6 mm and 8 mm tube ends  
1/4 in. NPT and BSPT pipe ends
  - RL4: 1/2 in. and 12 mm tube ends  
1/2 in. NPT pipe ends

### General Specifications

- Temperature Range: -40 to 300°F (-40 to 148°C)
- Valves preset to a specified set pressure are available
- Wide range of O-ring and seat materials
- Choice of Duolok, Griplok and Unilok tube end connections
- 316 SS valve bodies

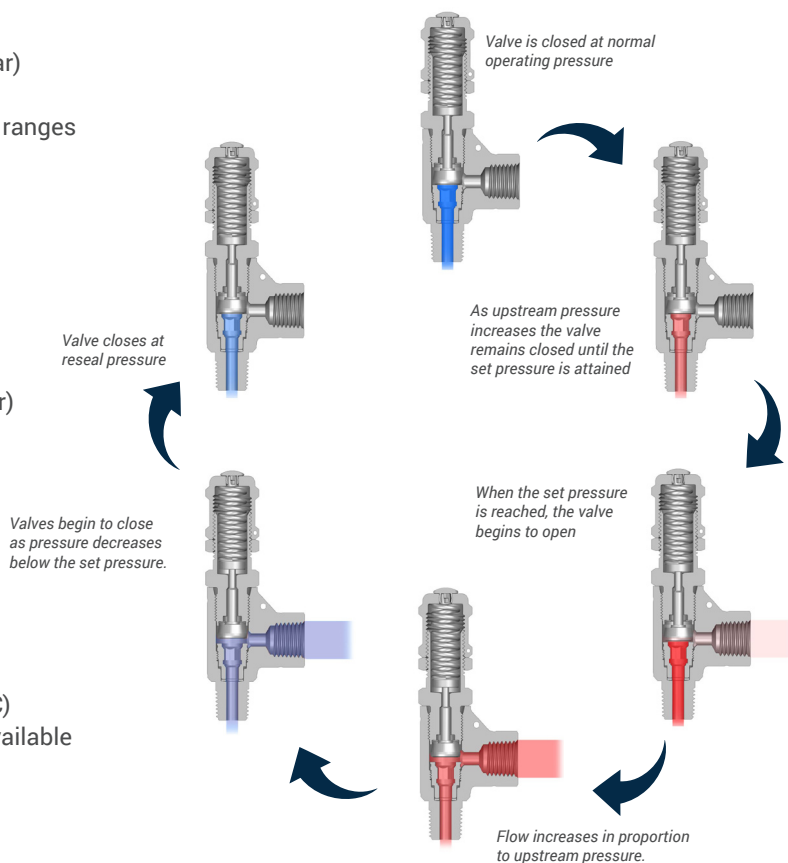

## Applications

R Series valves are used in gas or liquid systems in upstream and downstream oil & gas, chemical, pharmaceutical and laboratory applications. They are often used downstream from pumps and regulators to ensure protection from pressure spikes due to failures upstream of the valve or blockages downstream of the valve. Other applications include test labs, steam cleaning and sterilization systems, heating lines, dispensing and filling systems.

# Product Design

- 1 **CAP**  
Allows easy external set pressure adjustment.
- 2 **SPRING**  
Adjusts to provide set pressure. Springs are color coded to indicate the set pressure range.
- 3 **LABEL**  
Identifies spring set pressure range. Label colors are matched with the spring colors.
- 4 **LOCKNUT**  
Maintains cap position to lock in the pressure setting.
- 5 **LOCK WIRE CAPABILITY**  
Secures cap to maintain set pressure.
- 6 **STEM SEAL**  
Quad seal reduces friction for greater accuracy.
- 7 **O-RING**  
Fully supported O-ring provides durable elastomer seal for positive shutoff. See below for other designs.

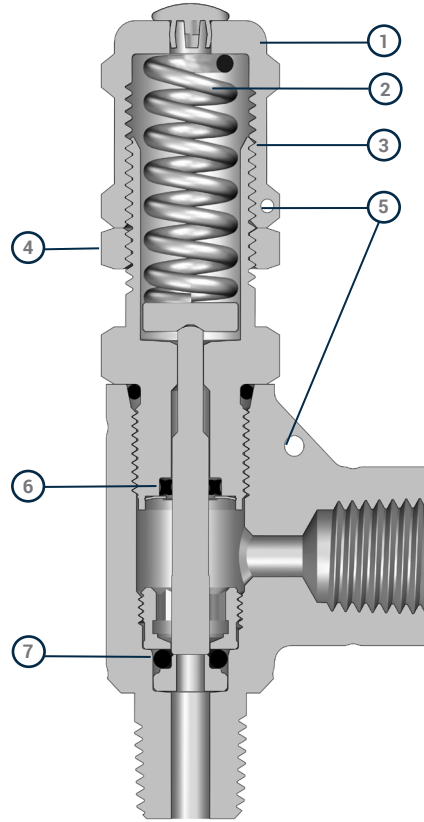

RH Series

Meets ASME B31.3 design pressure calculations

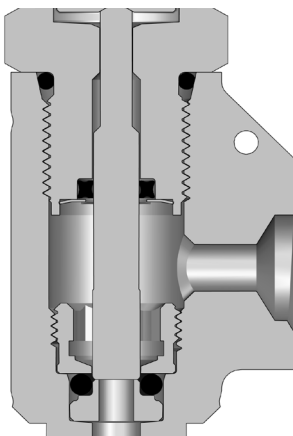

RH3

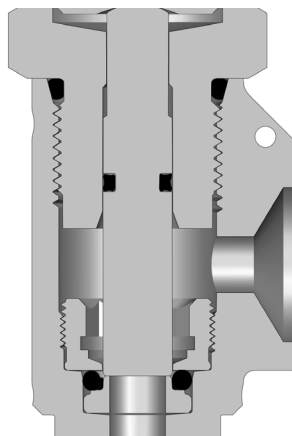

RH4

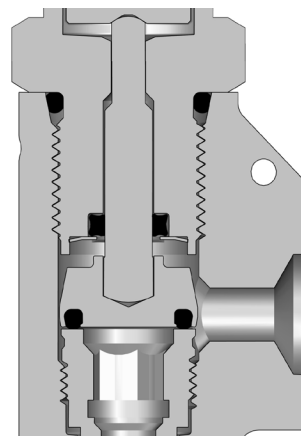

RL3

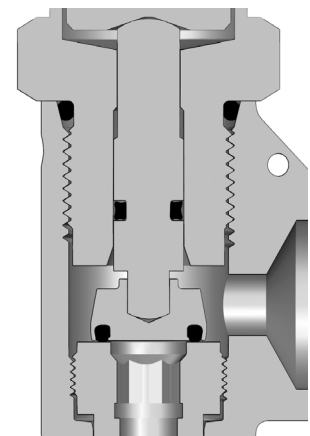

RL4

Series

# Technical Information

## General Specification

Series	RH3	RH4	RL3 / RL4
	psig, (bar)		
Max. Working Pressure	6000 (413) <sup>1</sup>	6000 (413)	300 (20.6)
Max. Outlet Pressure <sup>2</sup>	1500 (103)	2500 (172)	225 (15.5)
Set Pressure Range	50 to 6000 (3.4 to 413)	50 to 1500 (3.4 to 103)	10 to 225 (0.7 to 15.5)

<sup>1</sup> Up to 8000 psig (551 bar) during relief RH3 only

<sup>2</sup> Outlet pressure not to exceed inlet pressure

## Pressure - Temperature

Seal Materials	RH Series			RL Series	
	Temperature Range °F (°C)	RH3	RH4	Temperature Range °F (°C)	RL3 & RL4
		Max Set Pressure, psig (bar)			Max Set Pressure, psig (bar)
Fluorocarbon FKM	25 to 300 (-4 to 148)	6000 (413)	1500 (103)	10 to 275 (-12 to 135)	225 (15.3)
Nitrile	0 to 250 (-17 to 121)	6000 (413)	1500 (103)	-10 to 250 (-23 to 121)	
Ethylene Propylene	30 to 250 (-1 to 121)	6000 (413)	1500 (103)	-40 to 250 (-40 to 121)	
Perfluoroelastomer FFKM	30 (-1)	2500 (172)	1500 (103)	30 to 200 (-1 to 93)	225 (15.3)
	40 (4)	6000 (413)			
	70 (21)	6000 (413)			
	150 (65)	3000 (207)			
	200 (93)	1500 (103)			

## Set Pressure Repeatability

The table below estimates the repeatability of set pressure, the pressure at which flow begins, after initial actuation of the valve.

Temperature	Set Pressure Repeatability
60 to 80°F (15 to 26°C)	The greater of ± 3.0 psig (0.20 bar) or 5%
< 60°F (15°C)	The greater of ± 6.0 psig (0.40 bar) or 20%
> 80°F (26°C)	

**Note:** Valves that have not been actuated for a period of time may have higher initial cracking pressures.

## Resealing Pressure

The resealing pressure is the upstream pressure at which the valve closes and flow stops. It is always lower than set pressure. Every R series proportional relief valve is tested for set and resealing performance. The chart below provides parameters for resealing values within specific pressure ranges.

Series	Test Set Pressure psig (bar)	Minimum Resealing Pressure % of Set Pressure
RH3, RH4	100 to 200 (6.8 to 13.7)	50
	850 to 1000 (58.5 to 68.9)	85
RL3, RL4	10 to 20 (0.7 to 1.3)	50
	175 to 225 (12.0 to 15.5)	90

## Back Pressure

(RL Series Valves only)

System back pressure increases the set pressure of the RL Series valves. To compensate when setting the valve, subtract 80% of the back pressure from the desired set pressure.

### Example

- Desired set pressure: 200 psig.
- System back pressure: 60 psig.
- Set pressure:  $200 - (60 \times 0.80) = 152$  psig

**Note:** Valves are set at atmospheric outlet pressure.

## Cleaning and Packaging

R Series relief valves are cleaned and packaged according to SSP Standard Cleaning and Packaging Processes. Cleaning in accordance with ASTM G93 Level C, *Cleaning Methods and Cleanliness Levels for Material and Equipment Used in Oxygen-Enriched Environments* is also available.

# Technical Information

## Materials of Construction

ID	Component	Body Material
		316 SS
1	Plug	Nickel-Plated Steel
2	Cap	316 SS / A479
3	Label	Polyester
4	Lock Nut	316 SS / A479
5	Spring	S17700 / AMS 5678
6	Spring Support	316 SS / A479
7*	Bonnet	316 SS / A479
8*	O-ring	Fluorocarbon FKM
9*	Quad Seal	Low-Friction Coated Fluorocarbon FKM
10*	Retainer	316 SS / A666
11*	Stem	316 SS / A276
12*	Sealing Disc	Fluorocarbon FKM and 316 SS / A479
13*	Seat	316 SS / A479
14*	Gasket	PTFE-Coated 316 SS / A479
15*	Seat Retainer	316 SS / A479
16*	O-ring	Fluorocarbon FKM
17*	Insert	316 SS / A479
18*	Body	316 SS / A182
Lubricant		Molybdenum Disulfide-Based Dry Film and PTFE-Based

\*Wetted Components

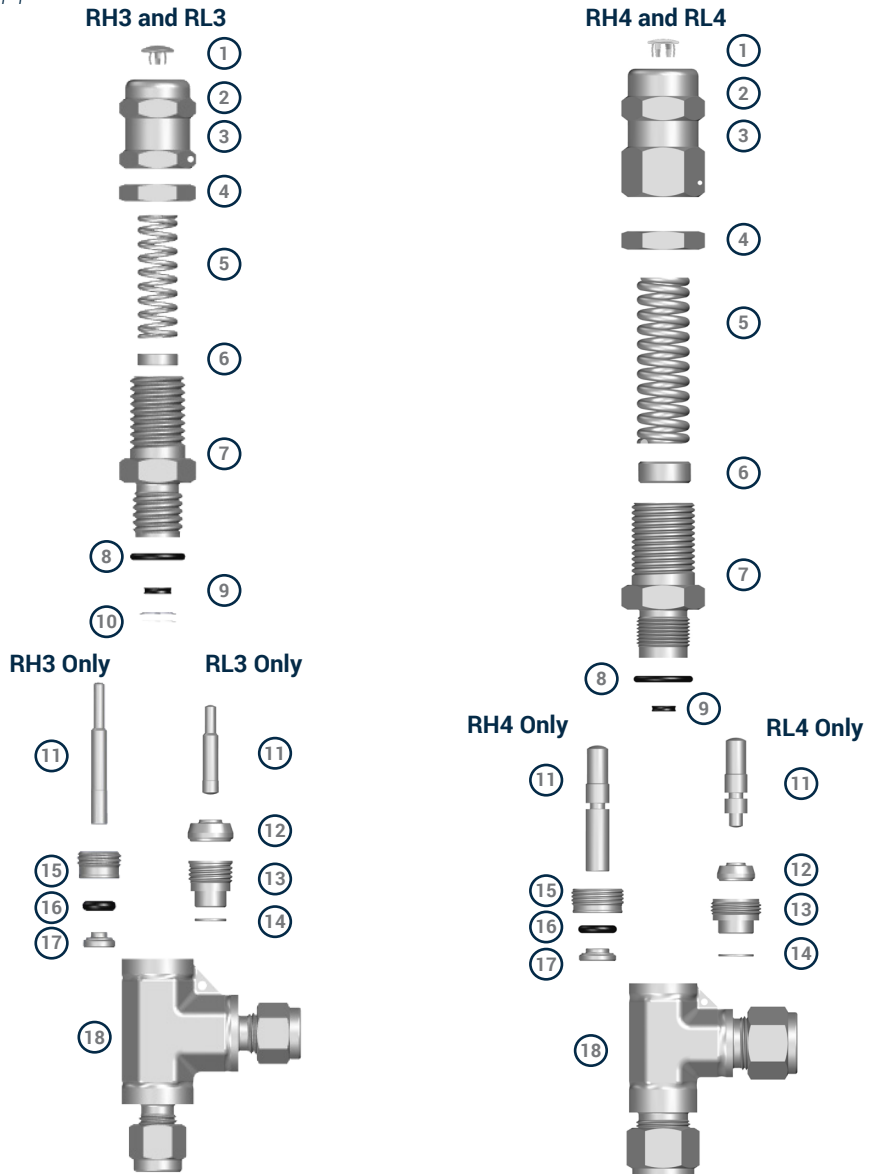

### Selection and Application

It is the system designer's responsibility to determine the requirements for their application and whether R Series relief valves conform to the codes.

In some systems, relief valves are required to meet specific safety codes which require valves to open completely at a set pressure. R series proportional relief valves open gradually as the pressure increases. Therefore they cannot be certified to ASME, PED, or any other codes for safety relief valves.

**SSP proportional relief valves should never be used as ASME Boiler and Pressure Vessel Code safety relief devices or as "Safety Accessories" defined in the Pressure Equipment Directive 97/23/EC.**

# Flow Data

(70°F/20°C)

## RH3 & RH4 Series

### Air Flow

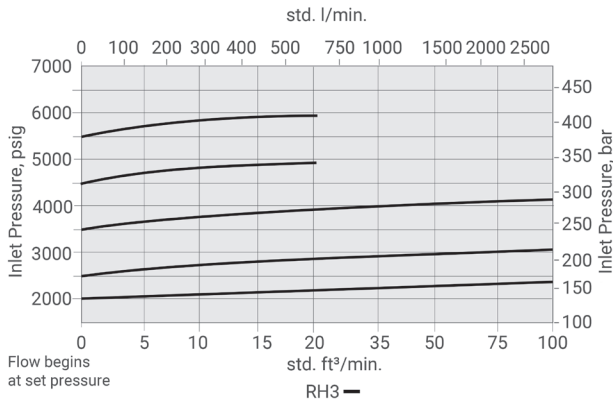

### Water Flow

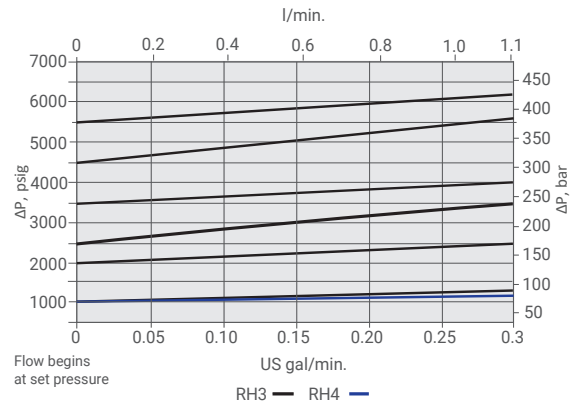

### Air Flow

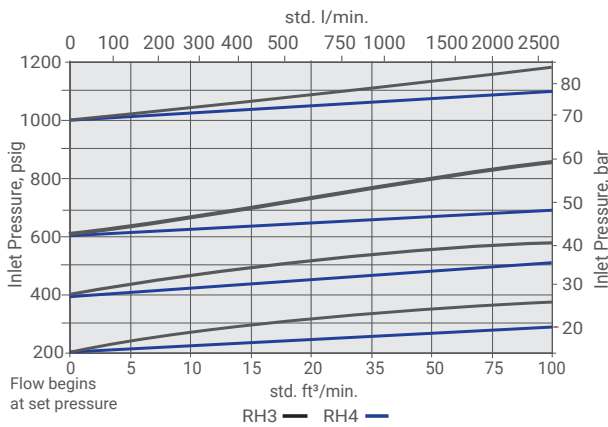

### Water Flow

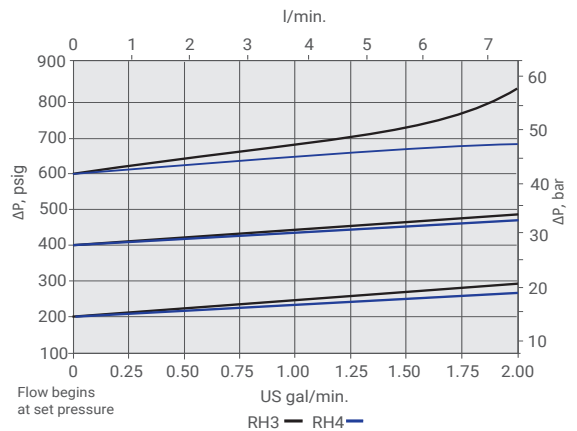

## RL3 & RL4 Series

### Air Flow

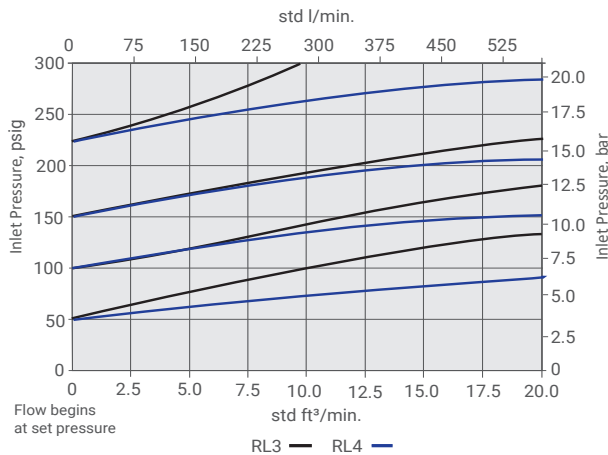

### Water Flow

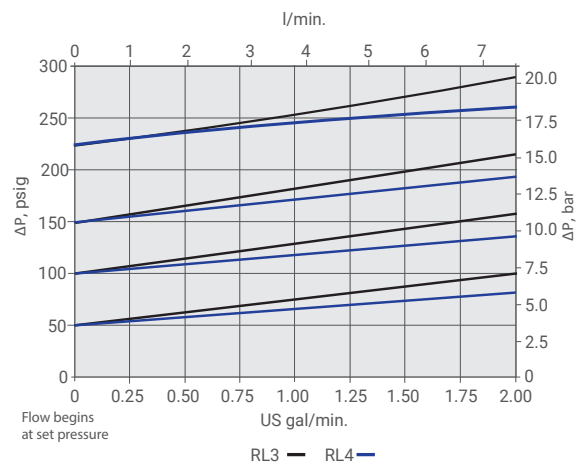

# Ordering Information

To order, locate the Basic Part Number for the valve for your application from the tables below, then add the required options and accessories from pages 9.

## Basic Part Numbers and Dimensions

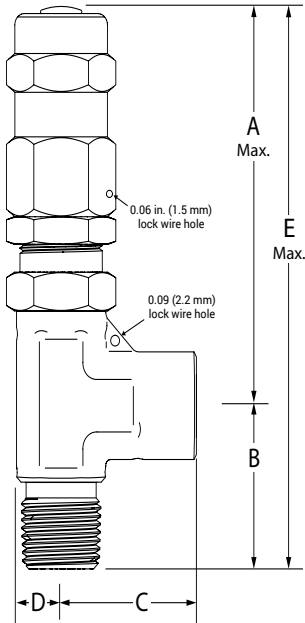

### RH3 and RH4 Series High Pressure Valves

**Note:** RH Series valves are shipped standard without springs. To order spring kits, valves with springs installed, or factory set valves, see the instructions on page 9.

Inlet/Outlet		Basic Part Number	Dimensions, in. (mm) <sup>1</sup>					
Type(s)	Size		A	B	C	D	E	H
Orifice 0.14 (3.6 mm), Set Pressures from 50 to 6000 psig (3.4 to 413 bar)								
Fractional Tube Fitting <sup>2</sup>	1/4 in.	RH3D4	2.70 (68.6)	1.44 (36.6)	1.60 (40.6)	0.41 (10.4)	4.14 (105)	4.09 (104)
Metric Tube Fitting <sup>2</sup>	6 mm	RH3DM6	2.70 (68.6)	1.44 (36.6)	1.60 (40.6)	0.41 (10.4)	4.14 (105)	4.09 (104)
	8 mm	RH3DM8	2.70 (68.6)	1.44 (36.6)	1.60 (40.6)	0.41 (10.4)	4.14 (105)	4.09 (104)
Male NPT to Tube <sup>2</sup>	1/4 in.	RH34PMD4	2.70 (68.6)	1.19 (30.2)	1.60 (40.6)	0.41 (10.4)	3.89 (98.8)	4.09 (104)
Male NPT to Female NPT	1/4 in.	RH34PM4PF	2.70 (68.6)	1.19 (30.2)	1.17 (29.7)	0.41 (10.4)	3.89 (98.8)	4.09 (104)
Male BSPT to Female BSPT	1/4 in.	RH34MRT4FRT	2.70 (68.6)	1.19 (30.2)	1.17 (29.7)	0.41 (10.4)	3.89 (98.8)	4.09 (104)
Orifice 0.25 (6.4 mm), Set Pressures from 50 to 1500 psig (3.4 to 103 bar)								
Fractional Tube Fitting <sup>2</sup>	1/2 in.	RH4D8	4.09 (104)	1.83 (46.5)	1.83 (46.5)	0.47 (11.9)	5.92 (150)	5.37 (136)
Metric Tube Fitting <sup>2</sup>	12 mm	RH4DM12	4.09 (104)	1.83 (46.5)	1.83 (46.5)	0.47 (11.9)	5.92 (150)	5.37 (136)
Male NPT to Tube Fitting <sup>2</sup>	1/2 in.	RH48PMD8	4.09 (104)	1.43 (36.3)	1.83 (46.5)	0.47 (11.9)	5.52 (140)	5.37 (136)
Male NPT to Female NPT	1/2 in.	RH48PM8PF	4.09 (104)	1.43 (36.3)	1.43 (36.3)	0.47 (11.9)	5.52 (140)	5.37 (136)

<sup>1</sup>Dimension are for reference only and subject to change.

<sup>2</sup>Basic part numbers specify Duolok two-ferrule tube ends. For Unilok single-ferrule or Griplik dual ferrule, see page 9.

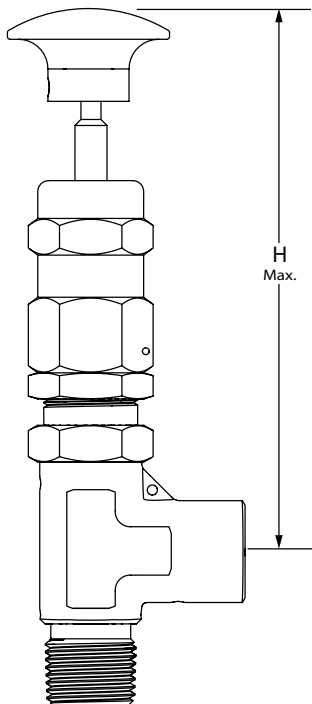

### RL3 and RL4 Series Low Pressure Valves

**Note:** RL Series valves are shipped standard with springs installed in the valve.

Inlet /Outlet		Basic Part Number	Dimensions, in. (mm) <sup>1</sup>					
Type(s)	Size		A	B	C	D	E	H
Orifice 0.19 (4.8 mm), Set Pressures from 10 to 225 psig (0.7 to 15.5 bar)								
Fractional Tube Fitting <sup>2</sup>	1/4 in.	RL3D4	2.70 (68.6)	1.44 (36.6)	1.60 (40.6)	0.41 (10.4)	4.14 (105)	4.09 (104)
Metric Tube Fitting <sup>2</sup>	6 mm	RL3DM6	2.70 (68.6)	1.44 (36.6)	1.60 (40.6)	0.41 (10.4)	4.14 (105)	4.09 (104)
	8 mm	RL3DM8	2.70 (68.6)	1.44 (36.6)	1.60 (40.6)	0.41 (10.4)	4.14 (105)	4.09 (104)
Male NPT to Tube Fitting <sup>2</sup>	1/4 in.	RL34PMD4	2.70 (68.6)	1.19 (30.2)	1.60 (40.6)	0.41 (10.4)	4.14 (105)	4.09 (104)
Male NPT to Female NPT	1/4 in.	RL34PM4PF	2.70 (68.6)	1.19 (30.2)	1.17 (29.7)	0.41 (10.4)	3.89 (98.8)	4.09 (104)
Male BSPT to Female BSPT	1/4 in.	RL34MRT4FRT	2.70 (68.6)	1.19 (30.2)	1.17 (29.7)	0.41 (10.4)	3.89 (98.8)	4.09 (104)
Orifice 0.25 (6.4 mm), Set Pressures from 10 to 225 psig (0.7 to 15.5 bar)								
Fractional Tube Fitting <sup>2</sup>	1/2 in.	RL4D8	4.09 (104)	1.83 (46.5)	1.83 (46.5)	0.47 (11.9)	5.92 (150)	5.37 (136)
Metric Tube Fitting <sup>2</sup>	12 mm	RL4DM12	4.09 (104)	1.83 (46.5)	1.83 (46.5)	0.47 (11.9)	5.92 (150)	5.37 (136)
Male NPT to Tube Fitting <sup>2</sup>	1/2 in.	RL48PMD8	4.09 (104)	1.43 (36.3)	1.83 (46.5)	0.47 (11.9)	5.52 (140)	5.37 (136)
Male NPT to Female NPT	1/2 in.	RL48PM8PF	4.09 (104)	1.43 (36.3)	1.43 (36.3)	0.47 (11.9)	5.52 (140)	5.37 (136)

<sup>1</sup>Dimension are for reference only and subject to change.

<sup>2</sup>Base part numbers specify Duolok two-ferrule tube ends. For Unilok single-ferrule or Griplik dual ferrule, see page 9.

# Options & Accessories

## Spring Options

RL Series valves are shipped with springs installed.

RH Series valves are shipped standard without springs. To order RH Series valves with factory installed springs locate the required pressure range from the table below then insert the spring designator into the part number.

Example: **RH3D4-316-C**

Set Pressure Range psig (bar)	Spring Designator	Spring Color
RH3		
50 to 350 (3.4 to 24.1)	-A	Blue
350 to 750 (24.1 to 51.7)	-B	Yellow
750 to 1500 (51.7 to 103)	-C	Purple
1500 to 2250 (103 to 155)	-D	Orange
2250 to 3000 (155 to 206)	-E	Brown
3000 to 4000 (206 to 275)	-F	White
4000 to 5000 (275 to 344)	-G	Red
5000 to 6000 (344 to 413)	-H	Green
RH4		
50 to 350 (3.4 to 24.1)	-A	Blue
350 to 750 (24.1 to 51.7)	-B	Yellow
750 to 1500 (51.7 to 103)	-C	Purple
RL3 / RL4		
10 to 225 (0.7 to 15.5)	Blank	N/A

## Spring Kits

Spring kits include the spring, spring support, label, 302 SS lock-wire with seal, and installation instructions.

To order spring kits, use the series and size followed by "-SK-177." For RH Series valves add the spring designator from the Spring Options table above.

Examples: **RH4-SK-177-C**

**RL4-SK-177**

## Manual Override Handles

A manual override handle allows operators to open the valve without changing the set pressure. To order relief valves with manual override handles, add -MO to the part number. Example: **RH4D4-316-MO**

Manual override handles can only be used with:

- RH3 series—A, B, and C springs only
- RH4 series—A spring only
- RL3 and RL4 series—standard spring

## Manual Override Handle Kits

Use the kit part number from the table below to order manual override kits for your valve series. Each kit contains an aluminum handle, 316 SS pull rod and instructions.

Series	Maximum Height (Closed Position)	Kit Part#
RH3, RL3	5.16 in. (131 mm)	R3-MOK
RH4, RL4	6.78 in. (172 mm)	R4-MOK

Handle diameter is 1.50 in. (38.1 mm).

## Factory Set Valves

R Series valves are available preset to a specified set pressure. Valves are set, tested, locked, and tagged with the set pressure. Certificates of testing are included. Allowable factory set pressure range is  $\pm 5\%$  from requested set pressure. To order preset RH Series valves, add the spring designator and the desired set pressure to the part number. For RL Series valves include the set pressure only.

Example **RH4D8-316-C850** or **RH4D8-316-C59BAR**

**RL3D4-316-100** or **RL4D8-316-7BAR**

## Tube Fitting End Connections

SSP offers three tube fitting designs. Duolok two-ferrule tube fittings are standard. To specify a different design, select the designator from the table below, then substitute it for the "D" in the part number. Example: **RL3U4-316**

Design	Description	Designator
Duolok	2-Ferrule	D
Unilok	1-Ferrule	U
Griplok	2-Ferrule	G

## Seal Materials

The standard seal material for R Series valves is Fluorocarbon FKM. To order non-standard seals, add the designator to the part number. Example: **RH3D4-316-BN**

Seal Material	Designator	
	Valve	Seal Kit
Fluorocarbon FKM	Blank	-V
Nitrile Rubber	-BN	
Ethylene Propylene	-EP	
Perfluoroelastomer FFKM	-FFKM	

## Seal Replacement Kits

To order a replacement seal kit, add a seal material designator from the seal material table into the seal kit basic ordering number from the table below.

Example: **RL3-RK-316-V**

RH3	RH4	RL3	RL4
Basic Part Number			
RH3-RK-316	RH4-RK-316	RL3-RK-316	RL4-RK-316
Kit Contents			
O-rings (2) Quad-Seal Retainer Instructions	O-rings (2) Quad-Seal Instructions	O-ring Quad-Seal Retainer Sealing Disc Instructions	O-ring Quad-Seal Sealing Disc Instructions

## Special Cleaning

Valves are available cleaned in compliance with ASTM G93 Level C and CGA G-4.1, *Cleaning Methods and Cleanliness Levels for Material and Equipment Used in Oxygen-Enriched Environments*. To specify, add -XP98 to the part number. Example: **RH3D4-316-XP98**

For more information about other types of special cleaning, please contact SSP Customer Service.

# Special Orders

The Basic Part Numbers and Dimensions tables contain only the most popular valve configurations; many more are available. If the required valve configuration is not in the Basic Part Numbers and Dimensions tables, use the chart below to build part numbers for quotation purposes.

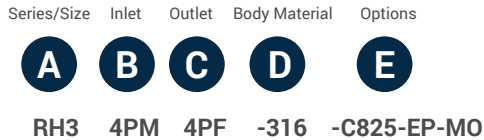

**A** SERIES / SIZE   **B** + **C** INLET<sup>1</sup> + OUTLET<sup>1</sup>

RL3 0.19 Orifice  
 RL4 0.25 Orifice  
 RH3 0.14 Orifice  
 RH4 0.25 Orifice

<b>Type:</b>	<b>Fractional Sizes:</b>	<b>Metric Sizes:</b>
D Duolok® Tube Fitting	4 1/4 in.	M6 6 mm
U Unilok® Tube Fitting	8 1/2 in.	M8 8 mm
G Griplok® Tube Fitting		M12 12 mm

**D** BODY MATERIAL

-316 316 SS

PF Female NPT  
 PM Male NPT  
 FRT Female BSPT  
 MRT Male BSPT

**E** OPTIONS<sup>2</sup>

**SPRINGS**

**Designator   Set Pressure Range**

RL3 & RL4 Series	psig (bar)
Blank	10 to 225 (0.7 to 15.5)
RH3 Series	psig (bar)
Blank	No Spring
-A	50 to 350 (3.4 to 24.1)
-B	350 to 750 (24.1 to 51.7)
-C	750 to 1500 (51.7 to 103)
-D	1500 to 2250 (103 to 155)
-E	2250 to 3000 (155 to 206)
-F	3000 to 4000 (206 to 275)
-G	4000 to 5000 (275 to 344)
-H	5000 to 6000 (344 to 413)
RH4 Series	psig (bar)
Blank	No Spring
-A	50 to 350 (3.4 to 24.1)
-B	350 to 750 (24.1 to 51.7)
-C	750 to 1500 (51.7 to 103)

**FACTORY SET PRESSURE**

Add the actual set pressure desired.  
 See page 9 for more information.

**SEAL MATERIALS**

Blank	Fluorocarbon FKM
-BN	Nitrile
-EP	Ethylene Propylene
-FFKM	Perfluoroelastomer FFKM

**OTHER OPTIONS**

-XP98 Special Cleaning per ASTM G93, Level C and CGA G-4.1  
 -MO Manual override handle.  
 See notes on page 9 for limitations.

<sup>1</sup> Tube fitting end connection part numbers are formatted Type followed by Size.

Example: **D4**

Pipe ends are formatted Size followed by Type. Example: **4PF**

If both ends are the same, use only one end connection designator.

Example: RL3**D4**-316

<sup>2</sup> Add options designators to the end of the Basic Part Number in alphabetical order.

## SSP Limited Lifetime Warranty

SSP valves are backed by the SSP Limited Lifetime Warranty.

This warranty is available from your local distributor or at [www.mySSP.com](http://www.mySSP.com).

## Important Information

IMPROPER SELECTION OR IMPROPER USE OF THE PRODUCTS DESCRIBED HEREIN OR RELATED ITEMS CAN CAUSE PERSONAL INJURY AND PROPERTY DAMAGE. It is the sole responsibility of the system designers and users to properly select and use products for their specific applications. This document has been provided to users with technical expertise as a reference for further investigation to determine specific product needs relative to their design requirements.

# More SSP Products



## Tube Fittings

Duolok® and Griplok® (two-ferrule) and Unilok® (single-ferrule) tube fittings ensure leak-tight installation when intermixed with Swagelok®, Hoke®, Gyrolok®, and Parker® CPI™ fittings, provided they are used in accordance with SSP Fittings' published installation and service recommendations.



## Valves

The SSP valve offering includes ball, check, metering, needle, toggle, plug, bleed, and purge valves for pressures up to 10,000 psig.



## Quick Connects

SSP offers single-end shutoff, double-end shut off, and full-flow quick connects for instrumentation and process applications.



## Pipe Fittings

TruFit and TruFit 10K pipe fittings are available in a wide range of weld, threaded and flared connections.



## Filters

SSP in-line and tee-type filters trap particles to clean sample fluids and protect sensitive process and analytical instrumentation components and equipment.



## Tools & Accessories

SSP TurnPro professional hand tools, power tools and installation training make quality tube system installation faster and easier.



# SSP

Founded 1926

Privately owned, third generation business

Modern single-site vertically integrated manufacturing facility

DFARS-compliant raw material

ISO 9001 quality management system

Limited Lifetime Warranty



8250 Boyle Parkway • Twinsburg, OH 44087

330-425-4250 • [www.mySSP.com](http://www.mySSP.com)