



SSP Valves



SSP Valves

- Check Valves
- Inline Filters
- Toggle Valves

- Needle, Metering & Lower Packing Valves
- Tee Filters





At SSP, we are proud to be an American manufacturing success story.

100% of our products are made in America. All of our manufacturing is performed in our 165,000 sq. ft. facility located near Cleveland, Ohio. Our facility is the largest vertically integrated, single-site operation in the industry. In addition to manufacturing and assembly, we have closed die forging, tool & die design, product engineering and testing operations under the same roof with customer service and management.

Made in America is good business. Not only do we make everything in America, we use American suppliers too. Buying American allows us to have better quality control and a more reliable supply chain. We can work more closely within our walls and with our suppliers to improve quality, reduce costs, and shorten lead times, which means faster service and better products for you.

SSP Industry Standard Products.
Made Better.

TABLE of CONTENTS

Valve Product Line	4	Metering Valves	16
Selection Guide	5	Needle Valves	21
Check Valves	6	Lower Packing Valves	24
Tee Filters	11	Toggle Valves	27
Inline Filters	13		

SSP Fittings Corp. (SSP)

Since its inception in 1926, SSP has developed into an internationally recognized manufacturer of the highest quality machined products.

This successful U.S. corporation's heritage of craftsmanship and business expertise provide the foundation for a valve division specializing in providing alternatives in quality instrumentation and process system valves,



tube, pipe, weld, hose and adapter fittings. SSP's world-renowned manufacturing, engineering, quality, sales and distribution now support valve product line expansion and provide the end-user with a single source for their instrumentation and process system valve and fitting needs.

SSP Valves

From its origination in 1960, SSP Valves have been manufactured to meet the highest quality and performance standards associated with the instrumentation, control, and process industry marketplace. The SSP product line was initiated and expanded in response to expressed needs for solutions in unique flow control applications. Out of its original beginnings of specialization, standard product lines became available to serve a wide variety of applications and customers. The broad offering of operating pressure and temperature ranges, flow control options and end connections has made SSP the product of choice for many applications. In 2001, the SSP valve product lines were acquired by SSP to supplement and complement SSP's historic product offering of quality.

NOTICE: SSP has made every reasonable effort to insure the accuracy of the information contained in this publication, and is not to be held liable in any manner for any mistakes, omissions, typographical and/or printing errors.



Product Line

Check Valves



- Pressures to 6000 psig
- Temperatures to 400°F
- O-ring Seat Seal
- 316 Stainless Steel
- Cracking Pressures: 1/3, 1, 5, 10, 15, 25, 50 psig
- **Standard Production Testing:** Every check valve is tested for crack and reseal performance

Toggle Valves



- Pressures to 200 psig
- Temperatures to 200°F
- FKM Seals
- PTFE Seat
- 316 Stainless Steel, Brass
- Straight & Angle Patterns
- **Standard Production Testing:** Every toggle valve is assembled and tested @ 200 psig with Nitrogen

Tee Filters



- Pressures to 5000 psig
- Temperatures to 450°F
- PTFE Gaskets
- 316 Stainless Steel, Brass
- Elements (Micron) 1, 2, 5, 10, 20, 40,60, 100,200,400
- Installation: The best installation practice to help proven contaminants from entering the system during element change is to orient the filter with the cap downwards

Inline Filters



- Pressures to 3000 psig
- Temperatures to 400°F
- Replaceable Filter Elements
- 316 Stainless Steel, Brass
- Elements (Micron) 1, 2, 5, 10, 20, 40,60, 100,200

Needle, Metering & Lower Packing Valves



- Pressures to 6000 psig
- Temperatures to 450°F
- Metal-to-Metal & Soft Seat Stems
- 316 Stainless Steel, Brass
- Straight & Angle Patterns
- **Standard Production Testing:** Every needle, metering and lower packing valve is assembled and tested @ 1000 psig with Nitrogen

Duolok®, Unilok®, Griplok® and Trufit® are registered trademarks of SSP Fittings Corp. Swagelok® and Cajon• are registered trademarks of the Swagelok Co. Hoke• and Gyrolok• are registered trademarks of Hoke Inc.

A-lok• and Parker CPI™ are registered trademarks of Parker Hannifin Corp. Viton™ is a registered trademark of DuPont. Kel-F™ is a registered trademark of 3M Company.

Selection Guide

<p>Check Valves CH & 4000 Series</p>  <p>6</p>	<p>Tee Filters 3000 Series</p>  <p>11</p>	<p>Inline Filters 3100 Series</p>  <p>13</p>	<p>Metering Valves 500 Series</p>  <p>16</p>
<p>Needle Valves 100 & 600 Series</p>  <p>21</p>	<p>Lower Packing Valves 400 Series</p>  <p>24</p>	<p>Toggle Valves 200 Series</p>  <p>27</p>	

End Connections

SSP valves are available with a choice of Duolok®, Unilok® and Griplok® fractional tube fittings and TruFit® pipe end connections.

Duolok®

Tube fitting end connections directly interchangeable/intermixable with Swagelok® tube fittings.



Griplok®

Tube fitting end connections directly interchangeable/intermixable with Hoke® Gyrolok® tube fittings.

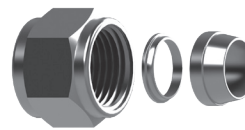

Unilok®

Tube fitting end connections directly interchangeable/intermixable with Parker CPI® tube fittings.



TruFit®

Pipe fitting end connections directly interchangeable with fittings provided by Swagelok®/Cajon®, Parker® and Hoke®.

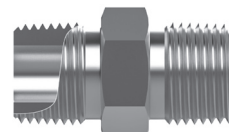

Duolok®, Unilok®, Griplok® and TruFit® are registered trademarks of SSP Fittings Corp. Swagelok® and Cajon® are registered trademarks of the Swagelok Co. Hoke® and Gyrolok® are registered trademarks of Hoke Inc.

A-lok® and Parker CPI® are registered trademarks of Parker Hannifin Corp. Viton™ is a registered trademark of DuPont. Kel-F™ is a registered trademark of 3M Company.

CH Series Check Valves

High-Pressure Check Valves

CH Series check valves are designed for high pressure, high cycle applications up to 6000 psig (413 bar). They are available with a variety of O-ring materials. Standard cracking pressures range from 1/3 to 25 psig (0.03 to 1.7 bar).



Product Design

- ① O-ring
 - Wide variety of o-ring materials
 - Easy maintenance
- ② O-ring Retainer
 - Fully supports the O-ring to prevent extrusion
- ③ Poppet Style Design
 - Vee shape maximizes sealing area
- ④ Gasket Seal
 - Metal to metal seal to the environment

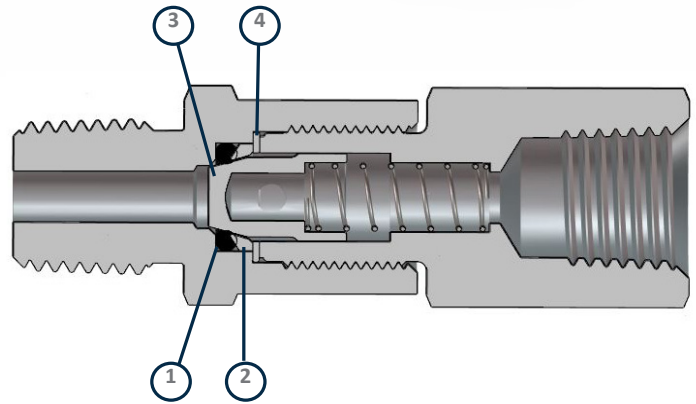

Cracking & Reseal Pressures

Nominal Cracking Pressure psig (bar)	Cracking Pressure Range psig (bar)	Reseal Pressure psig (bar)
1/3 (0.03)	Up to 3 (0.21)	Up to 6 (0.42) back pressure
1 (0.07)	Up to 4 (0.28)	Up to 5 (0.35) back pressure
5 (0.35)	3 TO 9 (0.21 TO 0.63)	Up to 2 (0.14) back pressure
10 (0.69)	7 TO 15 (0.49 TO 1.1)	3 (0.21) or more upstream pressure
25 (1.7)	20 TO 30 (1.4 TO 2.1)	17 (1.2) or more upstream pressure

When valves remain inactive for an extended duration, the initial cracking pressure might exceed the predetermined cracking pressure.

O-rings

Material	Temperature Rating °F (°C)
Fluorocarbon FKM (STD)	-10 TO 400 (-23 TO 204)
Nitrile	-20 TO 250 (-28 TO 121)
Low-Temp Nitrile	-40 TO 250 (-40 TO 121)
Ethylene Propylene	-50 TO 250 (-45 TO 121)
Kalrez	0 TO 400 (-17 TO 204)

Pressure - Temperature & Flow

Series	Maximum Flow Coefficient (Cv)	Downstream Pressure at 70°F (20°C) psig (bar)
CH4	0.60	6000 (413 bar)
CH8	2.15	
CH16	3.25	5000 (345 bar)

PRODUCTION TESTING

Check valves are 100% factory tested with nitrogen to confirm cracking pressure, reseal pressure, and for shell leakage at 1000 psi.

Materials of Construction

ID	Component	Material
1	Inlet Body	316 SS
2	O-ring	Fluorocarbon FKM
3	O-ring Retainer	316 SS
4	Connector Gasket	316 SS
5	Poppet	316 SS
6	Spring	302 SS
7	Outlet Body	316 SS

All components are wetted

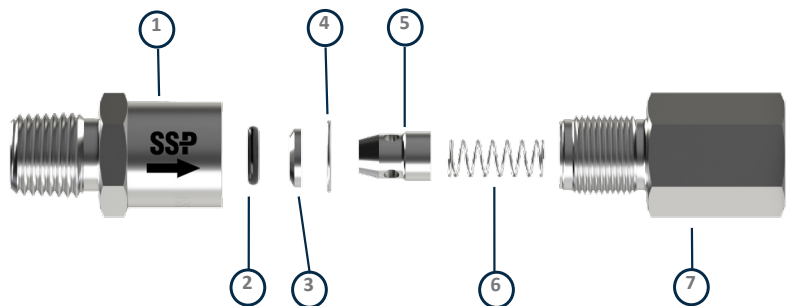

How to Order

CH Series Check Valves

Ordering Instructions

- 1 Select the basic part number from the Part Numbers and Dimensions table . Example: **CH4-D4**
Default tube end connections are Duolok. For Unilok or Griplok, add U or G to the basic part number.
CH4-U4 (Unilok), CH4-G4 (Griplok)
- 2 Select the cracking pressure designator, then add it to the part number. Example: **CH4-D4-1**
- 3 Select the material designator, then add it to the part number. Example: **CH4-D4-1-316**
- 4 Add additional options and accessories in alphabetical order. Example: **CH4-D4-1-316-BN-XP98**



Part Numbers and Dimensions

End Connections		Basic Part Number	Valve Series	Dimensions	
Type Inlet / Outlet	Size			A in. (mm)	B Hex in.
Fractional Tube Fitting	1/8	CH4-D2	CH4	2.27 (57.7)	11/16
	1/4	CH4-D4		2.44 (62.0)	11/16
	3/8	CH8-D6	CH8	2.75 (69.9)	1
	1/2	CH8-D8		2.96 (75.2)	1
	3/4	CH16-D12	CH16	3.53 (89.7)	1 - 3/4
1	CH16-D16	3.88 (98.6)		1 - 3/4	
Metric Tube Fitting	6	CH4-DM6	CH4	2.44 (62.0)	11/16
	8	CH8-DM8	CH8	2.70 (68.6)	1
	10	CH8-DM10		2.75 (69.9)	1
	12	CH8-DM12		2.96 (75.2)	1
Female NPT	1/4	CH4-4PF	CH4	2.26 (57.4)	11/16
	3/8	CH8-6PF	CH8	2.55 (67.8)	1
	1/2	CH8-8PF		3.03 (77.0)	1 - 1/16
	3/4	CH16-12PF	CH16	3.23 (82.0)	1 - 3/4
	1	CH16-16PF		3.83 (97.3)	1 - 3/4
Female ISO Tapered	1/4	CH4-4FRT	CH4	2.38 (60.5)	11/16
	3/8	CH8-6FRT	CH8	2.86 (72.6)	1
	1/2	CH8-8FRT		3.29 (83.6)	1 - 1/16
Male NPT	1/8	CH4-2PM	CH4	1.9 (48.3)	11/16
	1/4	CH4-4PM		2.17 (55.1)	11/16
	3/8	CH8-6PM	CH8	2.36 (59.9)	1
	1/2	CH8-8PM		2.73 (69.3)	1
	3/4	CH16-12PM	CH16	3.23 (82.0)	1 - 3/4
	1	CH16-16PM		3.67 (93.2)	1 - 3/4
Male ISO Tapered	1/4	CH4-4MRT	CH4	2.17 (55.1)	11/16
	1/2	CH8-8MRT	CH8	2.73 (69.3)	1
Male NPT to Female NPT	1/4	CH4-4PM4PF	CH4	2.26 (57.4)	11/16
	1/2	CH8-8PM8PF	CH8	2.89 (73.4)	1 - 1/16
Fractional Tube to Male NPT	3/8	CH8-D66PM		CH8	2.56 (65.0)
	1/2	CH8-D88PM	2.74 (69.6)		1

A BASIC PART NUMBER
See Chart

B CRACKING PRESSURE

- 1/3 1/3 PSI
- 1 1 PSI
- 5 5 PSI
- 10 10 PSI
- 25 25 PSI

C BODY MATERIAL

- 316 Stainless Steel

Other materials available upon request

D OPTIONS

O-rings

- Blank Fluorocarbon FKM (STD)
- BN Nitrile
- NBR3 Low-Temp Nitrile
- EP Ethylene Propylene
- KZ Kalrez

Special Cleaning

- XP98 ASTM G93, Level C and CGA G-4.1

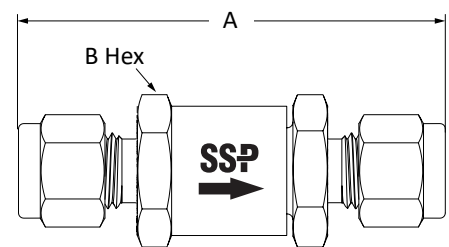
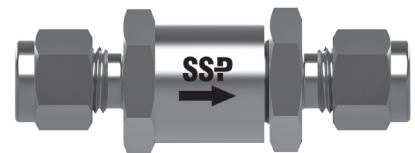

! Check valves are intended solely for regulating directional flow. It is essential to avoid utilizing SSP Check Valves as a substitute for safety relief devices as per industry standards.

4000 Series

Ball Poppet Check Valves

4000 Series ball poppet check valves control back flow and maintain upstream pressure in applications have working pressures up to 6000 psig (413 bar) and temperatures from -15 to 350° F (-26 to 176°C).



Product Design

- ① Fully Contained O-rings
 - Prevents O-ring extrusion and blow-out
- ② Caged Ball
 - Reliable cracking and resealing
 - Prevents over-stressing of the seal
- ③ Stem
 - Prevents spring over-compression
- ④ Variety of End Connections

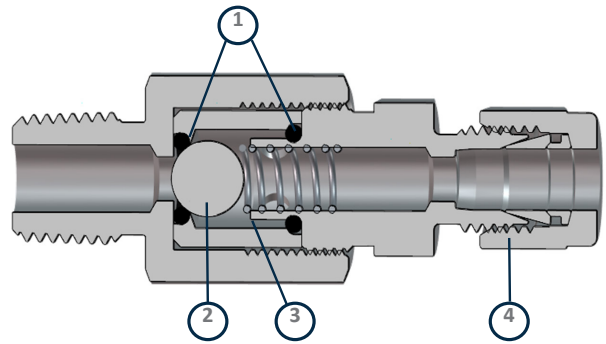

Cracking & Reseal Pressures

Nominal Cracking Pressure psig (bar)	Cracking Pressure Range psig (bar)	Reseal Pressure psig (bar)
1/3 (0.03)	Up to 1 (0.07)	Up to 6 (0.42) back pressure
1 (0.07)	Up to 3 (0.21)	Up to 6 (0.42) back pressure
10 (0.69)	7 TO 15 (0.49 TO 1.1)	3 (0.21) or more upstream pressure
25 (1.7)	20 TO 30 (1.4 TO 2.1)	17 (1.2) or more upstream pressure

Pressure - Temperature Chart

	Stainless Steel
Temp Rating	-15°F to 350°F
Pressure Rating @ 100°F	6,000 psig

Materials of Construction

ID	Component	Body Material
		Stainless Steel
1	Inlet Body	316 SS
2	O-ring	Fluorocarbon FKM
3	Ball Cage	316 SS
4	Ball	316 SS
5	Spring	316 SS
6	O-ring	Fluorocarbon FKM
7	Outlet Body	316 SS

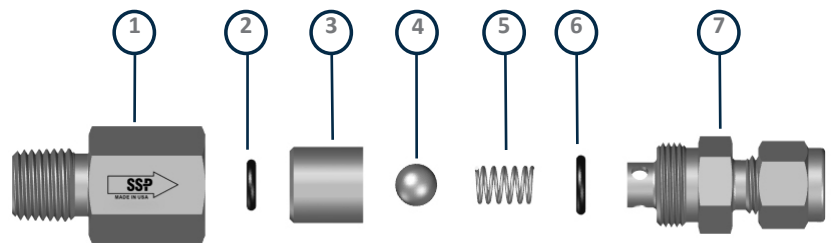

How to Order

Ball Poppet Check Valves

Ordering Instructions

- 1 Locate the basic part number for the valve with the required end connection type and size from the table below. *Example: 4012*
- 2 Add designator for the required cracking pressure. *Example: 4012-10*
- 3 Add the body material designator to the part number. *Example: 4012-10-316*
- 4 Add additional options and accessories in alphabetical order. *Example: 4012-10-316-XP98*



A BASIC PART NUMBER
40XX See Chart

B CRACKING PRESSURE
-1/3 1/3 PSI
-1 1 PSI
-10 10 PSI

C BODY MATERIAL
-316 Stainless Steel
-B Brass

D OPTIONS
SPECIAL CLEANING
-XP98 ASTM G93, Level C and CGA G-4.1

Part Numbers and Dimensions

END CONNECTION			Basic Part Number	Orifice in. (mm)	Cv	DIMENSIONS	
Type	Inlet Size	Outlet Size				A in. (mm)	B Hex in.
Fractional Tube Fitting	1/8	1/8	4002	0.09 (2.36)	0.66	2.6 (66.14)	3/4
	1/4	1/4	4012	0.19 (4.78)	0.66	2.67 (67.79)	3/4
	3/8	3/8	4022	0.28 (7.16)	1.08	3.06 (77.8)	7/8
	1/2	1/2	4032	0.28 (7.16)	1.08	3.29 (83.44)	7/8
Fractional Tube Fitting to Female NPT	1/4	1/8	4013	0.19 (4.78)	0.66	2.5 (63.5)	3/4
	1/2	1/2	4042	0.28 (7.16)	1.08	3.29 (83.57)	7/8
Fractional Tube Fitting to Male NPT	1/8	1/8	4005	0.09 (2.36)	0.66	2.44 (61.98)	3/4
	1/4	1/8	4011	0.19 (4.78)	0.66	2.5 (63.5)	3/4
	1/4	1/4	4015	0.19 (4.78)	0.66	2.5 (63.5)	3/4
	3/8	1/2	4023	0.28 (7.16)	1.08	3.05 (77.47)	7/8
	1/2	1/2	4031	0.28 (7.16)	1.08	3.17 (80.52)	7/8

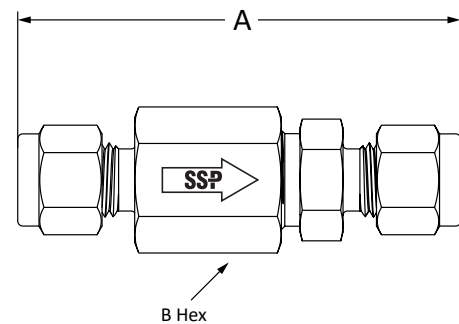

When valves remain inactive for an extended duration, the initial cracking pressure might exceed the predetermined cracking pressure.



Check valves are intended solely for regulating directional flow. It is essential to avoid utilizing SSP Check Valves as a substitute for safety relief devices as per industry standards.

4000 Series

Part Numbers and Dimensions

END CONNECTION			Basic Part Number	Orifice	CV	DIMENSIONS	
Type	Inlet Size	Outlet Size				A in. (mm)	B Hex in.
Female NPT	1/8	1/8	4010	0.19 (4.78)	0.66	2.33 (59.16)	3/4
	1/4	1/4	4020	0.19 (4.78)	0.66	2.71 (68.71)	3/4
	3/8	3/8	4030	0.28 (7.16)	1.08	2.92 (74.17)	7/8
	1/2	1/2	4040	0.28 (7.16)	1.08	3.33 (84.53)	1 - 1/8
Male NPT to Female NPT	1/8	1/8	4009	0.19 (4.78)	0.66	2.33 (59.18)	3/4
	1/4	1/4	4021	0.19 (4.78)	0.66	2.58 (65.53)	3/4
	3/8	3/8	4027	0.28 (7.16)	1.08	2.92 (74.17)	7/8
	1/2	3/8	4037	0.28 (7.16)	1.08	2.92 (74.17)	7/8
	1/2	1/2	4039	0.28 (7.16)	1.08	3.05 (77.47)	7/8
Male NPT	1/8	1/8	4006	0.19 (4.78)	0.66	2.33 (59.18)	3/4
	1/4	1/4	4016	0.19 (4.78)	0.66	2.33 (59.16)	3/4
	3/8	3/8	4026	0.28 (7.16)	1.08	2.8 (70.99)	7/8
	1/2	1/2	4036	0.28 (7.16)	1.08	2.92 (74.17)	7/8
Male NPT to Fractional Tube Fitting	1/8	1/8	4004	0.09 (2.36)	0.66	2.5 (63.5)	3/4
	1/8	1/4	4007	0.19 (4.78)	0.66	2.5 (63.5)	3/4
	1/4	1/4	4014	0.19 (4.78)	0.66	2.5 (63.45)	3/4
	3/8	3/8	4024	0.28 (7.16)	1.08	2.93 (74.4)	7/8
	3/8	1/2	4033	0.28 (7.16)	1.08	3.04 (77.22)	7/8
	1/2	1/2	4034	0.28 (7.16)	1.08	2.92 (74.17)	7/8
	1/2	3/8	4035	0.28 (7.16)	1.08	3.04 (77.22)	7/8
Female NPT to Male NPT	1/8	1/8	4008	0.19 (4.78)	0.66	2.33 (59.18)	3/4
	1/4	1/8	4017	0.19 (4.78)	0.66	2.46 (62.48)	3/4
	1/4	1/4	4018	0.19 (4.78)	0.66	2.45 (62.33)	3/4
	3/8	3/8	4028	0.28 (7.16)	1.08	2.8 (70.99)	7/8
	1/2	1/2	4038	0.28 (7.16)	1.08	3.2 (81.36)	1 - 1/8
Female NPT to Fractional Tube Fitting	1/8	1/4	4003	0.19 (4.78)	0.66	2.5 (63.5)	3/4
	1/4	1/4	4019	0.19 (4.78)	0.66	2.62 (66.55)	3/4
	3/8	3/8	4029	0.28 (7.16)	1.08	2.93 (74.42)	7/8
	1/2	1/2	4041	0.28 (7.16)	1.08	3.32 (84.33)	1 - 1/8

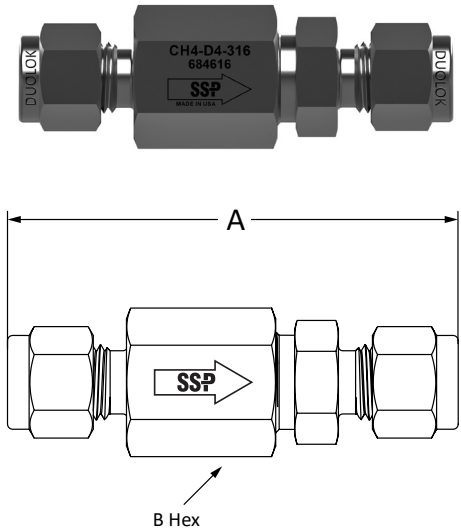

Tee Filters

3000 Series Tee-Type Particle Filters

Tee Filters are designed to remove unwanted particle impurities from samples in addition to protecting analyzers and other sensitive system components and equipment. Tee filter filtration elements can be changed without removing the filter from the system.



Product Design

- 1 Replacement of filter element without removing filter body from system
- 2 Available in 316 Stainless Steel and Brass
- 3 Replaceable sintered or strainer elements are available in choice of micron sizes
- 4 Choice of Duolok®, Unilok®, Griplok® tube fittings and TruFit® NPT pipe end connections

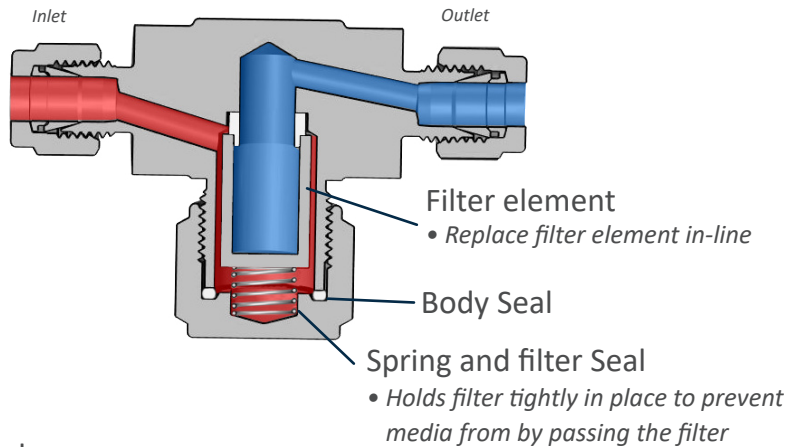

Materials of Construction

ID	Component	316 SS	Brass
1	Body*	316 SS	Brass
2	Filter Seal*	PTFE	PTFE
3	Filter Element*	316 SS	316 SS
3A	Strainer Cap*	PTFE	PTFE
4	Spring*	316 SS	316 SS
5	Body Seal*	PTFE	PTFE
6	Cap*	316 SS	Brass

*Wetted Components

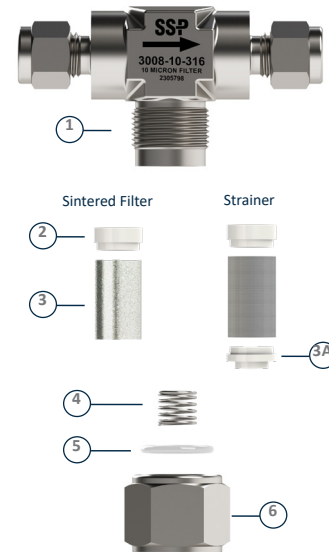

Filtration Definitions

- **Micron** - A unit of measure used to describe the mean particle diameter of media contamination or the mean pore diameter of the filter element. (1 micron = 0.001mm)
- **Filter Element** - The component of a filter that captures the contaminants. Available as sintered element or strainer.

Pressure - Temperature Chart

	Stainless Steel	Brass
Temp Rating	-20°F to 450°F	-20°F to 400°F
Pressure Rating @ 100°F	5,000 psig	3,000 psig

Sintered

- Traps fine contamination particles
- Choice of micron sizes (1 to 200)
- 316 Stainless Steel

Strainer

- Effectively removes large particles
- Choice of micron sizes (140 or 400)
- 316 Stainless Steel

How to Order

3000 Series Tee-Type Particle Filters

Ordering Instructions

- 1 Select the basic part number from the Part Numbers and Dimensions table based on the end connections for the filter. Example: **3008**
- 2 Select the micron element size designator, then add it the part number. Example: **3008-10**
- 3 Select the material designator, then add it the part number. Example: **3008-10-316**
- 4 Add additional options and accessories in alphabetical order.
Example: **3008-10-316-XP98**



A - **B** - **C** - **D**
3008 - **-10** - **-316**

A BASIC PART NUMBER
 See Chart

B FILTER ELEMENT

Sintered	-1	-40	Strainer	-140
	-2	-60		-400
	-5	-100		
	-10	-200		
	-20			

C BODY MATERIAL

-316	Stainless Steel
-B	Brass

D OPTIONS

SPECIAL CLEANING

- XP98 ASTM G93, Level C and CGA G-4.1
- XP97 ASTM G93, Level C and CGA G-4.1 No Lube
- LE Less Element

3000 Series

Part Numbers and Dimensions

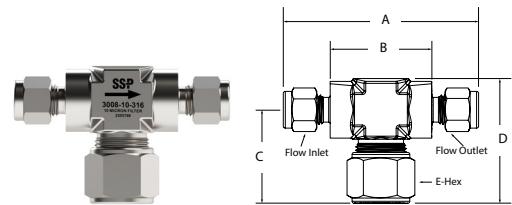

End Connection			Basic Part Number	Orifice in. (mm)	Dimensions, in. (mm)				
Type	Inlet Size	Outlet Size			A	B	C	D	E
Fractional Tube Fitting	1/8	1/8	3000	0.078 (2.0)	2.71 (68.9)	1.50 (38.2)	1.38 (35.1)	1.82 (46.6)	7/8 (22.2)
	1/4	1/4	3008	0.156 (4.0)	2.91 (73.9)	1.51 (38.4)	1.38 (35.1)	1.82 (46.6)	7/8 (22.2)
	3/8	3/8	3016	0.172 (4.4)	2.77 (70.3)	1.25 (31.8)	1.38 (35.1)	1.82 (46.6)	7/8 (22.2)
	1/2	1/2	3020	0.172 (4.4)	2.99 (76.0)	1.25 (31.8)	1.38 (35.1)	1.82 (46.6)	7/8 (22.2)
Female NPT	1/4	1/4	3014	0.172 (4.4)	2.25 (57.2)	0.81 (20.5)	1.38 (35.1)	1.82 (46.6)	7/8 (22.2)
Male NPT	1/8	1/8	3004	0.156 (4.0)	2.19 (55.6)	1.41 (35.7)	1.38 (35.1)	1.82 (46.6)	7/8 (22.2)
	1/4	1/4	3012	0.140 (3.6)	2.19 (55.6)	1.05 (26.6)	1.38 (35.1)	1.82 (46.6)	7/8 (22.2)
	3/8	3/8	3019	0.172 (4.4)	2.25 (57.2)	1.11 (28.2)	1.38 (35.1)	1.82 (46.6)	7/8 (22.2)
Male NPT to Fractional Tube Fitting	1/4	1/4	3010	0.156 (4.0)	2.48 (63.0)	1.21 (30.8)	1.38 (35.1)	1.82 (46.6)	7/8 (22.2)
	3/8	3/8	3018	0.172 (4.4)	2.51 (63.7)	1.18 (30)	1.38 (35.1)	1.82 (46.6)	7/8 (22.2)

Inline Filters

3100 Series Inline Filters



Inline filters remove system contaminants and maintain fluid purity in instrumentation and process systems. Sintered metal and mesh elements trap particles to protect sensitive equipment such as sensors and analyzers. Inline filters are used where more direct flow through the filter and compact size are required.

Product Design

- 1 MAWP: Up to 3000 psig (206 bar)
- 2 Temperature: -20°F to 400° F
- 3 Liquid and gas service
- 4 End Connections: Duolok®, Unilok®, Griplok® tube fittings, tube adapters, and TruFit® NPT pipe end connections
- 5 Body Materials: 316 SS, Brass
- 6 Sintered Metal Filter element sizes: 1 to 200 microns.

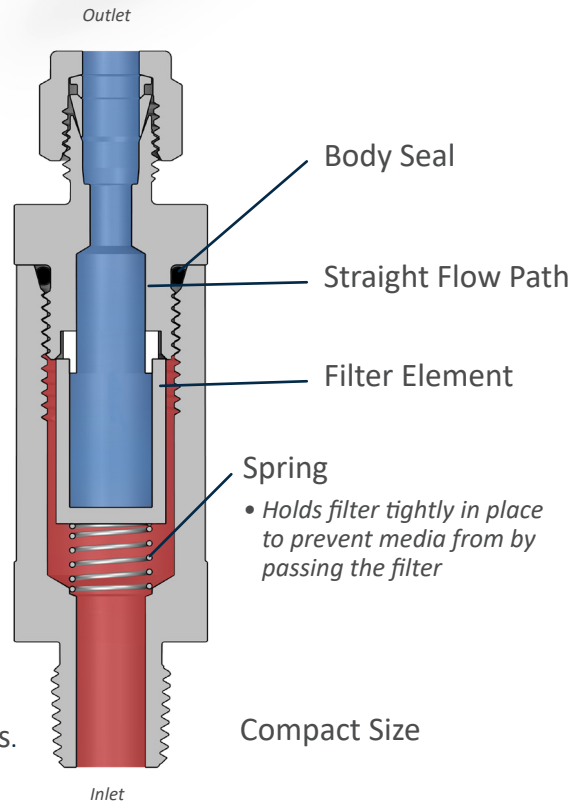

Materials of Construction

ID	Component	316 SS	Brass
1	Body*	316 SS	Brass
2	Filter Seal*	PTFE	PTFE
3	Filter Element*	316 SS	316 SS
3A	Strainer Cap*	PTFE	PTFE
4	Spring*	316 SS	316 SS
5	Body Seal*	FKM	FKM
6	Body Connector*	316 SS	Brass

Pressure - Temperature Chart

	Stainless Steel	Brass
Temp Rating	-20°F to 400°F	-20°F to 300°F
Pressure Rating @ 100°F	3,000 psig	1,000 psig

*Wetted Components

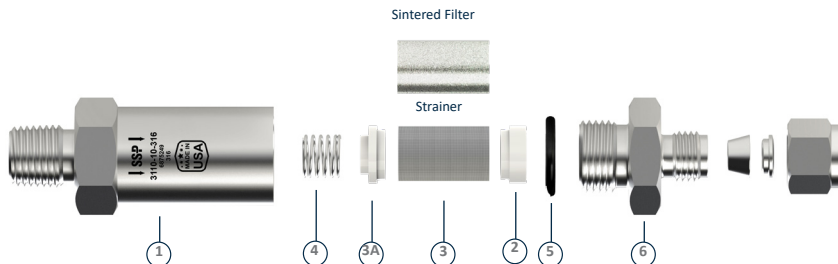

How to Order

3100 Series Inline Filters



Ordering Instructions

- 1 Select the basic part number from the Part Numbers and Dimensions table based on the end connections and orifice size for the valve. *Example: 3108*
- 2 Select the micron element size designator, then add it the part number. *Example: 3108-10*
- 3 Select the material designator, then add it the part number. *Example: 3108-10-316*
- 4 Add additional options and accessories in alphabetical order. *Example: 3108-10-316-XP98*

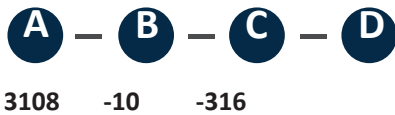

A BASIC PART NUMBER
See Chart

B FILTER ELEMENT

<i>Sintered</i>	-1	-40	<i>Strainer</i>	-140
	-2	-60		-400
	-5	-100		
	-10	-200		
	-20			

C BODY MATERIAL

-316	<i>Stainless Steel</i>
-B	<i>Brass</i>

D OPTIONS

SPECIAL CLEANING

-XP98	<i>ASTM G93, Level C and CGA G-4.1</i>
-XP97	<i>ASTM G93, Level C and CGA G-4.1 No Lube</i>
-LE	<i>Less Element</i>

Filtration Definitions

Micron - A unit of measure used to describe the mean particle diameter of media contamination or the mean pore diameter of the filter element. (1 micron = 0.001mm)

Filter Element - The component of a filter that captures the contaminants. Available as sintered element or strainer.

Sintered

- Traps fine contamination particles
- Choice of micron sizes (1 to 200)
- 316 Stainless Steel

Strainer

- Effectively removes large particles
- Choice of micron sizes (140 or 400)
- 316 Stainless Steel

3100 Series

Part Numbers and Dimensions

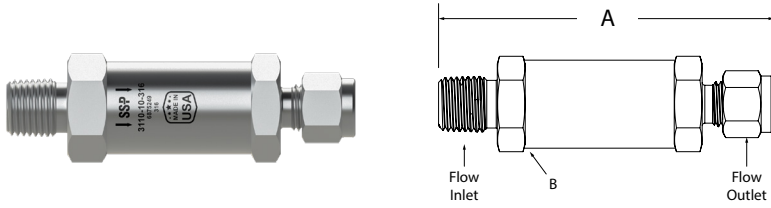

Type	End Connection		Basic Part Number	Orifice in. (mm)	Dimensions, in. (mm)	
	Inlet Size	Outlet Size			A	B
Fractional Tube Fitting	1/8	1/8	3100	0.095 (2.41)	3.15 (79.9)	7/8 (22.2)
	1/4	1/4	3108	0.189 (4.80)	3.33 (84.6)	7/8 (22.2)
	3/8	3/8	3116	0.312 (7.93)	3.46 (87.9)	7/8 (22.2)
	1/2	1/2	3120	0.312 (7.93)	3.67 (93.2)	7/8 (22.2)
Female NPT	1/8	1/8	3106	0.312 (7.93)	2.57 (65.3)	7/8 (22.2)
	1/4	1/4	3114	0.312 (7.93)	2.88 (73.2)	7/8 (22.2)
	1/2	1/2	3115	0.312 (7.93)	3.46 (87.9)	1 - 1/16 (27)
Male NPT	1/8	1/8	3104	0.295 (7.49)	2.59 (65.8)	7/8 (22.2)
	1/4	1/4	3112	0.312 (7.92)	3.09 (78.5)	7/8 (22.2)
	3/8	3/8	3119	0.312 (7.92)	3.09 (78.5)	7/8 (22.2)
Male NPT to Fractional Tube Fitting	1/4	1/4	3110	0.189 (4.80)	3.26 (82.8)	7/8 (22.2)
	3/8	3/8	3118	0.312 (7.92)	3.32 (84.3)	7/8 (22.2)

Metering Valves

500 Series Metering Valves

500 Series Metering Valves are designed for analyzers, instrumentation, laboratory, and other applications where accurate control of flow is required.



Product Design

- 1 MAWP: Up to 6000 psig
- 2 Temperature: -40° to 450°F (-40 to 316°C)
- 3 Stem Angles:
 - 8° Standard (0.47 orifice)
 - 10° Standard (All other orifice sizes)
 - 2° Optional (All orifice sizes)
- 4 Orifice Sizes: From 0.047" to 0.250"
- 5 Body Materials: 316 SS, and Brass
- 6 Packing Materials: PTFE
- 7 Straight and angle patterns
- 8 End Connections: Duolok, Griplok, Unilok tube end, and NPT and BSPT pipe ends.
- 9 End connection Sizes:
 - 1/8 to 1/2 in.
- 10 Handles: Stainless Vernier, Knurled, and T-bar

Chrome Plated Stem

- Increased durability
- Greater corrosion resistance

Live Loaded Packing

- Fully supported chevron packing
- Easy inline adjustment

Stem Angles

- 2", 8", 10", included angle

Durable Handle

- Brass insert
- Options
 - Stainless Steel T-bar
 - Stainless Steel Knurled
 - Vernier

Panel Mounting

- ### Precision Threads
- Precise regulation

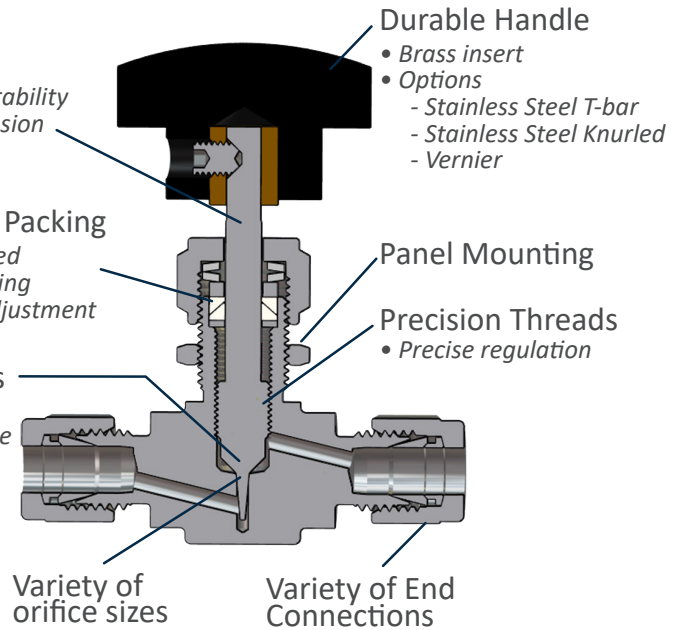

Pressure - Temperature Chart

	Stainless Steel	Brass
Temp Rating	-40°F to 450°F	-40°F to 450°F
Pressure Rating @ 100°F	6,000 psig	3,000 psig

Materials of Construction

ID	Component	316 SS	Brass
1	Body*	316 Stainless Steel	Brass
2	Panel Nut	316 Stainless Steel	Brass
3	Stem*	316 Stainless Steel	316 Stainless Steel
4	Packing Support*	316 Stainless Steel	316 Stainless Steel
5	Lower Packing*	PTFE	PTFE
6	Upper Packing*	PTFE	PTFE
7	Packing Pusher	316 Stainless Steel	316 Stainless Steel
8	Packing Springs	316 Stainless Steel	316 Stainless Steel
9	Packing Nut	316 Stainless Steel	Brass
10	Set Screw	Stainless Steel	Stainless Steel
11	Handle	Phenolic	Phenolic

*Wetted Components

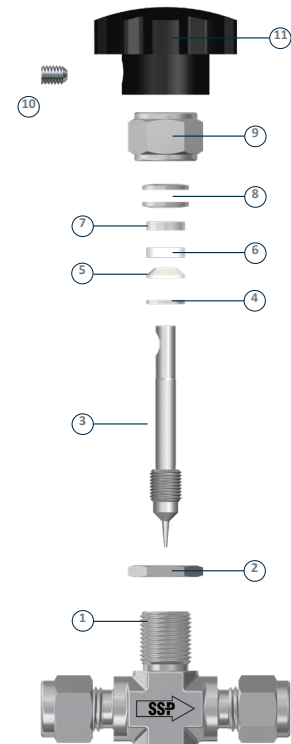

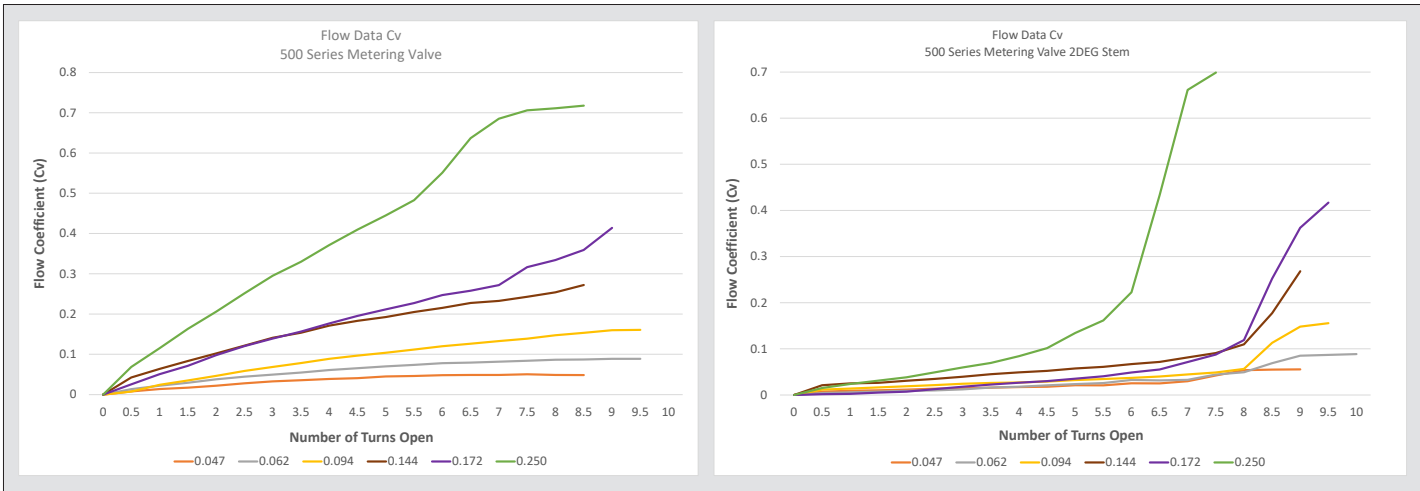

How to Order

500 Series Metering Valves

Ordering Instructions

- 1 Add the Angle Pattern Designator. Example **A**
- 2 Add the Basic Part Number. Example **A500**
- 3 Add the Material Designator. Example: **A500-316**
- 4 Add options from the Chart D. Example: **A500-316-TBH**



A **B** - **C** - **D**

A **500** -**316** -**TBH**

A **ANGLE PATTERN**
 Blank Straight Pattern (Standard)
 A Angle Pattern

B **BASIC PART NUMBER**
 See chart below for Basic Ordering Number

C **MATERIAL**
 -B Brass
 -316 Stainless Steel

D **OPTIONS**

Handles	Tube End Connections	Stem Angle
Black Blank (Standard)	Duolok Blank (Standard)	2 Degree -2DEG
SS Tee Bar -TBH	Unilok -U	
VERNIER -MVH	Griplok -G	
SS Knurled -KH		

500 Series Metering Valves

Part Numbers and Dimensions

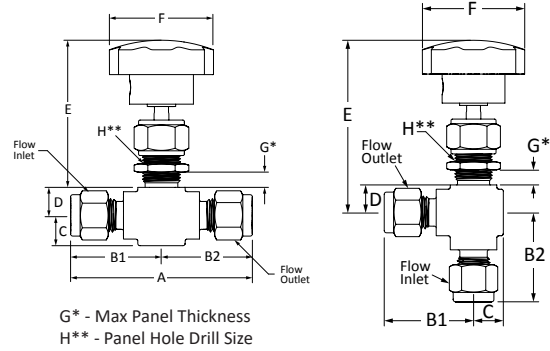

End Connection			Basic Part Number	Orifice	Dimensions, in. (mm)								
Type	Inlet Size	Outlet Size			A	B1	B2	C	D	E	F	G	H
Fractional Tube Fitting	1/8	1/8	504	0.047	2.34 (59.3)	1.17 (29.7)	1.17 (29.7)	0.4 (10.2)	0.38 (9.7)	2.75 (69.9)	1.38 (3.50)	0.38 (9.7)	17/32
	1/8	1/8	504-1	0.062	2.34 (59.3)	1.17 (29.7)	1.17 (29.7)	0.4 (10.2)	0.38 (9.7)	2.69 (68.4)	1.38 (3.50)	0.38 (9.7)	17/32
	1/4	1/4	506	0.047	2.4 (61.0)	1.2 (30.5)	1.2 (30.5)	0.4 (10.2)	0.38 (9.7)	2.75 (69.9)	1.38 (3.50)	0.38 (9.7)	17/32
	1/4	1/4	506-1	0.062	2.4 (61.0)	1.2 (30.5)	1.2 (30.5)	0.4 (10.2)	0.38 (9.7)	2.69 (68.4)	1.38 (3.50)	0.38 (9.7)	17/32
	1/4	1/4	506-5	0.094	2.4 (61.0)	1.2 (30.5)	1.2 (30.5)	0.4 (10.2)	0.38 (9.7)	2.69 (68.4)	1.38 (3.50)	0.38 (9.7)	17/32
	1/4	1/4	506-9	0.144	2.4 (61.0)	1.2 (30.5)	1.2 (30.5)	0.4 (10.2)	0.38 (9.7)	2.75 (69.9)	1.38 (3.50)	0.38 (9.7)	17/32
	1/4	1/4	506-11	0.172	2.4 (61.0)	1.2 (30.5)	1.2 (30.5)	0.4 (10.2)	0.38 (9.7)	2.75 (69.9)	1.38 (3.50)	0.38 (9.7)	17/32
Fractional Tube Fitting	3/8	3/8	512	0.047	2.4 (61.0)	1.2 (30.4)	1.2 (30.4)	0.4 (10.2)	0.38 (9.7)	2.75 (69.9)	1.38 (3.50)	0.38 (9.7)	17/32
	3/8	3/8	512-1	0.062	2.4 (61.0)	1.2 (30.4)	1.2 (30.4)	0.4 (10.2)	0.38 (9.7)	2.69 (68.4)	1.38 (3.50)	0.38 (9.7)	17/32
	3/8	3/8	512-5	0.094	2.4 (61.0)	1.2 (30.4)	1.2 (30.4)	0.4 (10.2)	0.38 (9.7)	2.69 (68.4)	1.38 (3.50)	0.38 (9.7)	17/32
	3/8	3/8	512-9	0.144	2.4 (61.0)	1.2 (30.5)	1.2 (30.4)	0.4 (10.2)	0.38 (9.7)	2.75 (69.9)	1.38 (3.50)	0.38 (9.7)	17/32
	3/8	3/8	512-11	0.172	2.4 (61.0)	1.2 (30.4)	1.2 (30.4)	0.4 (10.2)	0.38 (9.7)	2.75 (69.9)	1.38 (3.50)	0.38 (9.7)	17/32
	1/2	1/2	520	0.250	2.62 (66.4)	1.31 (33.2)	1.31 (33.3)	0.51 (13.0)	0.53 (13.5)	3.2 (81.3)	1.38 (35.0)	0.38 (9.7)	25/32

500 Series Metering Valves

Part Numbers and Dimensions

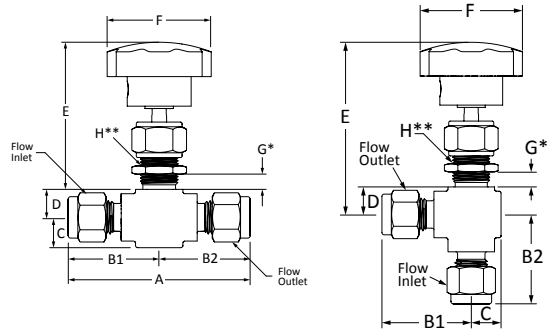

End Connection			Basic Part Number	Orifice	Dimensions, in. (mm)								
Type	Inlet Size	Outlet Size			A	B1	B2	C	D	E	F	G	H
Female NPT	1/8	1/8	510	0.047	1.82 (46.2)	0.91 (23.0)	0.91 (23.0)	0.4 (10.2)	0.38 (9.7)	2.75 (69.9)	1.38 (35.0)	0.38 (9.7)	17/32
	1/8	1/8	510-1	0.062	1.82 (46.2)	0.91 (23.0)	0.91 (23.0)	0.4 (10.2)	0.38 (9.7)	2.69 (68.4)	1.38 (35.0)	0.38 (9.7)	17/32
	1/8	1/8	510-5	0.094	1.82 (46.2)	0.91 (23.0)	0.91 (23.0)	0.4 (10.2)	0.38 (9.7)	2.69 (68.4)	1.38 (35.0)	0.38 (9.7)	17/32
	1/8	1/8	510-9	0.144	1.82 (46.2)	0.91 (23.0)	0.91 (23.0)	0.4 (10.2)	0.38 (9.7)	2.75 (69.9)	1.38 (35.0)	0.38 (9.7)	17/32
	1/8	1/8	510-11	0.172	1.82 (46.2)	0.91 (23.0)	0.91 (23.0)	0.4 (10.2)	0.38 (9.7)	2.75 (69.9)	1.38 (35.0)	0.38 (9.7)	17/32
	1/4	1/4	514	0.047	2 (50.8)	1 (25.4)	1 (25.4)	0.4 (10.2)	0.38 (9.7)	2.81 (71.4)	1.38 (35.0)	0.38 (9.7)	17/32
	1/4	1/4	514-1	0.062	2 (50.8)	1 (25.4)	1 (25.4)	0.4 (10.2)	0.38 (9.7)	2.75 (69.9)	1.38 (35.0)	0.38 (9.7)	17/32
	1/4	1/4	514-5	0.094	2 (50.8)	1 (25.4)	1 (25.4)	0.4 (10.2)	0.38 (9.7)	2.75 (69.9)	1.38 (35.0)	0.38 (9.7)	17/32
	1/4	1/4	514-11	0.172	2 (50.8)	1 (25.4)	1 (25.4)	0.4 (10.2)	0.38 (9.7)	2.81 (71.4)	1.38 (35.0)	0.38 (9.7)	17/32
	1/4	1/4	514-13	0.250	2.3 (58.4)	1.15 (29.2)	1.15 (29.2)	0.4 (10.2)	0.38 (9.7)	3.22 (81.7)	1.38 (35.0)	0.38 (9.7)	25/32

500 Series Metering Valves

Part Numbers and Dimensions

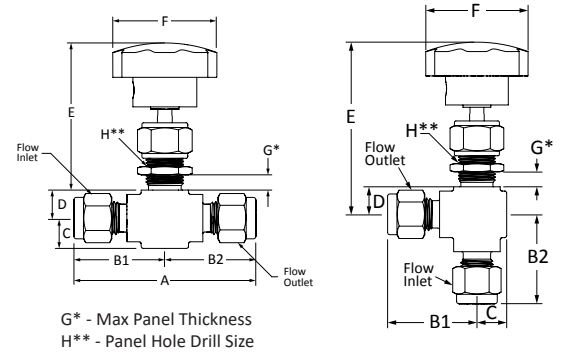

End Connection			Basic Part Number	Orifice	Dimensions, in. (mm)								
Type	Inlet Size	Outlet Size			A	B1	B2	C	D	E	F	G	H
Male NPT	1/8	1/8	500	0.047	1.81 (46.0)	0.91 (23.0)	0.91 (23.0)	0.4 (10.2)	0.38 (9.7)	2.75 (69.9)	1.38 (35.0)	0.38 (9.7)	17/32
	1/8	1/8	500-1	0.062	1.81 (46.0)	0.91 (23.0)	0.91 (23.0)	0.4 (10.2)	0.38 (9.7)	2.69 (68.4)	1.38 (35.0)	0.38 (9.7)	17/32
	1/8	1/8	500-5	0.094	1.81 (46.0)	0.91 (23.0)	0.91 (23.0)	0.4 (10.2)	0.38 (9.7)	2.69 (68.4)	1.38 (35.0)	0.38 (9.7)	17/32
	1/8	1/8	500-9	0.144	1.81 (46.0)	0.91 (23.0)	0.91 (23.0)	0.4 (10.2)	0.38 (9.7)	2.75 (69.9)	1.38 (35.0)	0.38 (9.7)	17/32
	1/4	1/4	502	0.047	1.81 (46.0)	0.91 (23.0)	0.91 (23.0)	0.4 (10.2)	0.38 (9.7)	2.75 (69.9)	1.38 (35.0)	0.38 (9.7)	17/32
	1/4	1/4	502-1	0.062	1.81 (46.0)	0.91 (23.0)	0.91 (23.0)	0.4 (10.2)	0.38 (9.7)	2.69 (68.4)	1.38 (35.0)	0.38 (9.7)	17/32
	1/4	1/4	502-5	0.094	1.81 (46.0)	0.91 (23.0)	0.91 (23.0)	0.4 (10.2)	0.38 (9.7)	2.69 (68.4)	1.38 (35.0)	0.38 (9.7)	17/32
	1/4	1/4	502-9	0.144	1.81 (46.0)	0.91 (23.0)	0.91 (23.0)	0.4 (10.2)	0.38 (9.7)	2.75 (69.9)	1.38 (35.0)	0.38 (9.7)	17/32
	1/4	1/4	502-11	0.172	1.81 (46.0)	0.91 (23.0)	0.91 (23.0)	0.4 (10.2)	0.38 (9.7)	2.75 (69.9)	1.38 (35.0)	0.38 (9.7)	17/32
Male NPT to Fractional Tube Fitting	1/8	1/4	508	0.047	2.11 (53.5)	0.91 (23.0)	1.2 (30.5)	0.4 (10.2)	0.38 (9.7)	2.75 (69.9)	1.38 (35.0)	0.38 (9.7)	17/32
	1/8	1/4	508-1	0.062	2.11 (53.5)	0.91 (23.0)	1.2 (30.5)	0.4 (10.2)	0.38 (9.7)	2.69 (68.4)	1.38 (35.0)	0.38 (9.7)	17/32
	1/8	1/4	508-5	0.094	2.11 (53.5)	0.91 (23.0)	1.2 (30.5)	0.4 (10.2)	0.38 (9.7)	2.69 (68.4)	1.38 (35.0)	0.38 (9.7)	17/32
	1/8	1/4	508-9	0.144	2.11 (53.5)	0.91 (23.0)	1.2 (30.5)	0.4 (10.2)	0.38 (9.7)	2.75 (69.9)	1.38 (35.0)	0.38 (9.7)	17/32
	1/4	1/4	509	0.047	2.11 (53.5)	0.91 (23.0)	1.2 (30.5)	0.4 (10.2)	0.38 (9.7)	2.75 (69.9)	1.38 (35.0)	0.38 (9.7)	17/32
	1/4	1/4	509-1	0.062	2.11 (53.5)	0.91 (23.0)	1.2 (30.5)	0.4 (10.2)	0.38 (9.7)	2.69 (68.4)	1.38 (35.0)	0.38 (9.7)	17/32
	1/4	1/4	509-5	0.094	2.11 (53.5)	0.91 (23.0)	1.2 (30.5)	0.4 (10.2)	0.38 (9.7)	2.69 (68.4)	1.38 (35.0)	0.38 (9.7)	17/32
	1/4	1/4	509-9	0.144	2.11 (53.5)	0.91 (23.0)	1.2 (30.5)	0.4 (10.2)	0.38 (9.7)	2.75 (69.9)	1.38 (35.0)	0.38 (9.7)	17/32
	1/4	1/4	509-11	0.172	2.11 (53.5)	0.91 (23.0)	1.2 (30.5)	0.4 (10.2)	0.38 (9.7)	2.75 (69.9)	1.38 (35.0)	0.38 (9.7)	17/32
	1/4	3/8	503	0.047	2.11 (53.5)	0.91 (23.0)	1.2 (30.5)	0.4 (10.2)	0.38 (9.7)	2.75 (69.9)	1.38 (35.0)	0.38 (9.7)	17/32
	1/4	3/8	503-1	0.062	2.11 (53.5)	0.91 (23.0)	1.2 (30.5)	0.4 (10.2)	0.38 (9.7)	2.69 (68.4)	1.38 (35.0)	0.38 (9.7)	17/32
	1/4	3/8	503-5	0.094	2.11 (53.5)	0.91 (23.0)	1.2 (30.5)	0.4 (10.2)	0.38 (9.7)	2.69 (68.4)	1.38 (35.0)	0.38 (9.7)	17/32
	1/4	3/8	503-9	0.144	2.11 (53.5)	0.91 (23.0)	1.2 (30.5)	0.4 (10.2)	0.38 (9.7)	2.75 (69.9)	1.38 (35.0)	0.38 (9.7)	17/32
	1/4	3/8	503-11	0.172	2.11 (53.5)	0.91 (23.0)	1.2 (30.5)	0.4 (10.2)	0.38 (9.7)	2.75 (69.9)	1.38 (35.0)	0.38 (9.7)	17/32

Needle Valves

100 & 600 Series Integral Bonnet Needle Valves

SSP Needle Valves are designed for positive shut-off and regulation control of media in instrumentation and process systems. With a variety of end connections, temperature ranges, and pressures, integral bonnet needle valves are used in a wide range of instrumentation, control, utility and mechanical systems.



Product Design

- 1 Live loaded Chevron packing**
 - Fully supported packing prevents extrusion.
 - Self-adjusting reduces maintenance and packing adjustments.
 - Easy inline adjustment
- 2 Chrome plated stem**
 - Greater corrosion and gall resistance for increased durability
 - Precision threads for leak-tight shut off

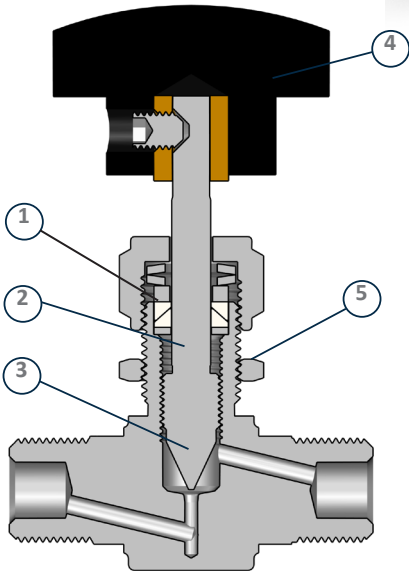

- 3 Stem tip**
 - Vee-tip
 - PCTFE
- 4 Durable Handle**
 - Nylon
 - Brass insert
 - Stainless steel knurled and T-bar handles available
- 5 Panel Mounting**

Pressure - Temperature Chart

Temp Rating	Stainless Steel		Brass	
	Metal Stem	-40°F to 450°F	Metal Stem	-40°F to 450°F
	Kel-F Stem Point	-40°F to 200°F	Kel-F Stem Point	-40°F to 200°F
Pressure Rating @ 100°F	6,000 psig		3,000 psig	

Materials of Construction

ID	Component	316 SS	Brass
1	Body*	316 Stainless Steel	Brass
2	Panel Nut	Stainless Steel	Brass
3	Stem*	316 Stainless Steel	316 Stainless Steel
4	Packing Support*	316 Stainless Steel	316 Stainless Steel
5	Lower Packing*	PTFE	PTFE
6	Upper Packing*	PTFE	PTFE
7	Packing Pusher	316 Stainless Steel	316 Stainless Steel
8	Packing Springs	316 Stainless Steel	316 Stainless Steel
9	Packing Nut	316 Stainless Steel	Brass
10	Set Screw	Stainless Steel	Stainless Steel
11	Handle	Phenolic	Phenolic

*Wetted Components

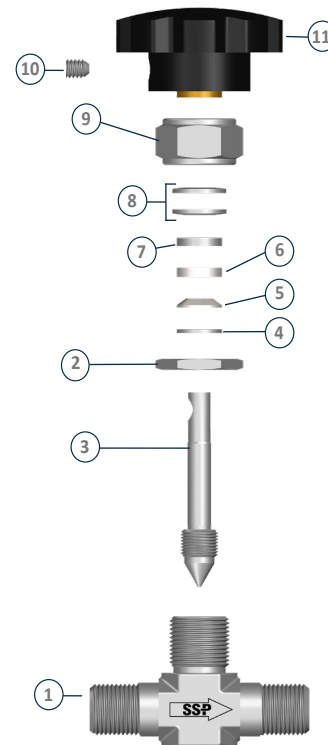

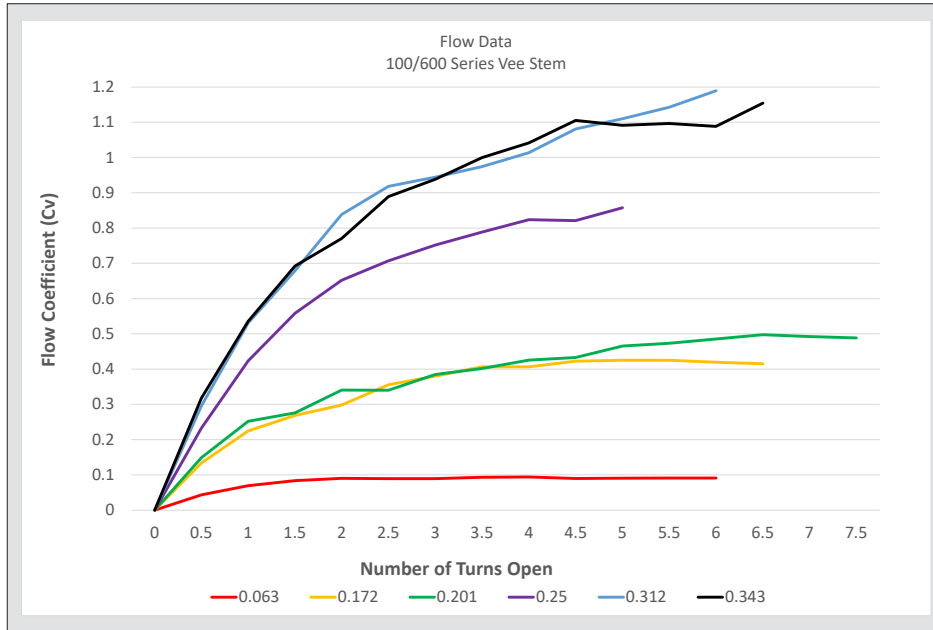

How to Order

100 & 600 Series Integral Bonnet Needle Valves

Ordering Instructions

- 1 Add the angle pattern designator. Example: **A**
- 2 Add the basic part number from the chart B. Example: **A118**
- 3 Add the stem type from chart C. Example: **A118-K**
- 4 Add the material designator from Chart D. Example: **A118-K-316**
- 5 Add options from the Chart E. Example: **118-K-316-TBH**

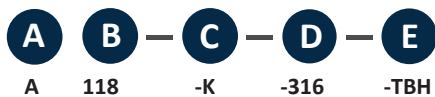

<p>A SHAPE Straight Blank Angle A</p>	<p>B BASIC PART NUMBER 100/600 Series See Chart</p>	<p>C STEM Vee-Tip PCTFE-Tip</p>	<p>D BODY MATERIAL 316 SS -316 Brass -B</p>								
<p>E OPTIONS</p> <table border="0"> <tr> <td>Handles</td> <td>Tube End Connections</td> </tr> <tr> <td>Black Blank (Standard)</td> <td>Duolok Blank (Standard)</td> </tr> <tr> <td>SS Tee Bar -TBH</td> <td>Unilok -U</td> </tr> <tr> <td>SS Knurled -KH</td> <td>Griplok -G</td> </tr> </table>				Handles	Tube End Connections	Black Blank (Standard)	Duolok Blank (Standard)	SS Tee Bar -TBH	Unilok -U	SS Knurled -KH	Griplok -G
Handles	Tube End Connections										
Black Blank (Standard)	Duolok Blank (Standard)										
SS Tee Bar -TBH	Unilok -U										
SS Knurled -KH	Griplok -G										

Part Numbers and Dimensions

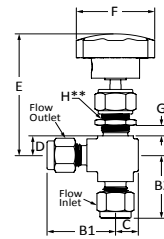
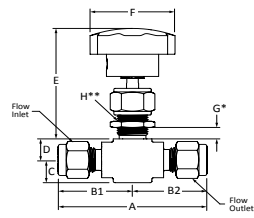
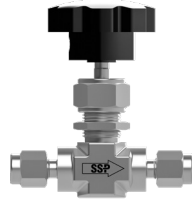

G* - Max Panel Thickness
H** - Panel Hole Drill Size

End Connection		Basic Part Number	Dimensions in. (mm)									
Inlet/Outlet	Size		Orifice	A	B1	B2	C	D	E	F	G	H
Fractional Tube Fitting	1/8	104	0.063	2.336 (59.33)	1.17 (29.72)	1.17 (29.72)	0.4 (10.16)	0.375 (9.53)	2.55 (64.77)	1.375 (34.93)	0.38 (9.65)	17/32 (13.49)
		106	0.063	2.4 (60.96)	1.2 (30.48)	1.2 (30.48)	0.4 (10.16)	0.375 (9.53)	2.55 (64.77)	1.375 (34.93)	0.38 (9.65)	17/32 (13.49)
	1/4	118	0.172	2.4 (60.96)	1.2 (30.48)	1.2 (30.48)	0.4 (10.16)	0.375 (9.53)	2.55 (64.77)	1.375 (34.93)	0.38 (9.65)	17/32 (13.49)
		124	0.172	2.4 (60.96)	1.196 (30.38)	1.196 (30.38)	0.4 (10.16)	0.375 (9.53)	2.55 (64.77)	1.375 (34.93)	0.38 (9.65)	17/32 (13.49)
	3/8	626	0.25	2.58 (65.53)	1.29 (32.77)	1.29 (32.77)	0.438 (11.13)	0.438 (11.13)	3.15 (80.01)	1.745 (44.32)	0.38 (9.65)	25/32 (19.84)
		651	0.25	2.804 (71.22)	1.402 (35.61)	1.402 (35.61)	0.438 (11.13)	0.438 (11.13)	3.15 (80.01)	1.745 (44.32)	0.38 (9.65)	25/32 (19.84)
	1/2	654	0.312	2.804 (71.22)	1.402 (35.61)	1.402 (35.61)	0.438 (11.13)	0.438 (11.13)	3.15 (80.01)	1.745 (44.32)	0.38 (9.65)	25/32 (19.84)
		657	0.343	2.804 (71.22)	1.402 (35.61)	1.402 (35.61)	0.438 (11.13)	0.438 (11.13)	3.15 (80.01)	1.745 (44.32)	0.38 (9.65)	25/32 (19.84)
Female NPT	1/8	110	0.06	1.82 (46.23)	0.91 (23.01)	0.91 (23.01)	0.4 (10.16)	0.38 (9.53)	2.55 (64.77)	1.38 (34.93)	0.38 (9.65)	17/32 (13.49)
		114	0.17	1.82 (46.23)	0.91 (23.01)	0.91 (23.01)	0.4 (10.16)	0.38 (9.53)	2.55 (64.77)	1.38 (34.93)	0.38 (9.65)	17/32 (13.49)
	1/4	600	0.06	2.00 (50.8)	1.00 (25.4)	1.00 (25.4)	0.44 (11.13)	0.44 (11.13)	2.61 (66.29)	1.38 (34.93)	0.38 (9.65)	17/32 (13.49)
		600-2	0.17	2.00 (50.8)	1.00 (25.4)	1.00 (25.4)	0.44 (11.13)	0.44 (11.13)	2.61 (66.29)	1.38 (34.93)	0.38 (9.65)	17/32 (13.49)
		600-3	0.201	2.00 (50.8)	1.00 (25.4)	1.00 (25.4)	0.44 (11.13)	0.44 (11.13)	2.61 (66.29)	1.38 (34.93)	0.38 (9.65)	17/32 (13.49)
	3/8	660	0.250	2.5 (63.5)	1.25 (31.75)	1.25 (31.75)	0.75 (19)	0.69 (17.42)	3.36 (85.34)	1.75 (44.32)	0.38 (9.65)	25/32 (19.84)
		660-2	0.31	2.5 (63.5)	1.25 (31.75)	1.25 (31.75)	0.75 (19)	0.69 (17.42)	3.36 (85.34)	1.75 (44.32)	0.38 (9.65)	25/32 (19.84)
		660-3	0.34	2.5 (63.5)	1.25 (31.75)	1.25 (31.75)	0.75 (19)	0.69 (17.42)	3.36 (85.34)	1.75 (44.32)	0.38 (9.65)	25/32 (19.84)
	1/2	664	0.25	2.62 (66.65)	1.31 (33.32)	1.31 (33.32)	0.75 (19.05)	0.69 (17.42)	3.36 (85.34)	1.75 (44.32)	0.38 (9.65)	25/32 (19.84)
		664-2	0.31	2.62 (66.65)	1.31 (33.32)	1.31 (33.32)	0.75 (19.05)	0.69 (17.42)	3.36 (85.34)	1.75 (44.32)	0.38 (9.65)	25/32 (19.84)
		664-3	0.34	2.62 (66.65)	1.31 (33.32)	1.31 (33.32)	0.75 (19.05)	0.69 (17.42)	3.36 (85.34)	1.75 (44.32)	0.38 (9.65)	25/32 (19.84)
	Male NPT	1/8	100	0.063 (1.6)	1.82 (46.23)	0.91 (23.01)	0.91 (23.01)	0.40 (10.16)	0.38 (9.53)	2.55 (64.77)	1.38 (34.93)	0.38 (9.65)
112			0.172 (4.37)	1.82 (46.23)	0.91 (23.01)	0.91 (23.01)	0.40 (10.16)	0.38 (9.53)	2.55 (64.77)	1.38 (34.93)	0.38 (9.65)	17/32 (13.49)
1/4		102	0.063 (1.6)	1.82 (46.23)	0.91 (23.01)	0.91 (23.01)	0.40 (10.16)	0.38 (9.53)	2.55 (64.77)	1.38 (34.93)	0.38 (9.65)	17/32 (13.49)
		116	0.172 (4.37)	1.82 (46.23)	0.91 (23.01)	0.91 (23.01)	0.40 (10.16)	0.38 (9.53)	2.55 (64.77)	1.38 (34.93)	0.38 (9.65)	17/32 (13.49)
3/8		636	0.25 (6.35)	2.28 (57.96)	1.14 (28.98)	1.14 (28.98)	0.44 (11.13)	0.44 (11.13)	3.15 (80.01)	1.75 (44.32)	0.38 (9.65)	25/32 (19.84)
Male NPT to Fractional Tube Fitting	1/8	105	0.063 (1.6)	2.08 (52.83)	0.91 (23.01)	1.17 (29.67)	0.40 (10.16)	0.38 (9.53)	2.55 (64.77)	1.38 (34.93)	0.38 (9.65)	17/32 (13.49)
	1/4	122	0.172 (4.37)	2.11 (53.59)	0.91 (23.01)	1.20 (30.48)	0.40 (10.16)	0.38 (9.53)	2.55 (64.77)	1.38 (34.93)	0.38 (9.65)	17/32 (13.49)
		123	0.172 (4.37)	2.11 (53.59)	0.91 (23.01)	1.20 (30.48)	0.40 (10.16)	0.38 (9.53)	2.55 (64.77)	1.38 (34.93)	0.38 (9.65)	17/32 (13.49)
Male NPT to Female NPT	1/4	603	0.063 (1.6)	2.00 (50.8)	1.00 (25.4)	1.00 (25.4)	0.44 (11.13)	0.44 (11.13)	2.61 (66.29)	1.38 (34.93)	0.38 (9.65)	17/32 (13.49)
		603-2	0.172 (4.37)	2.00 (50.8)	1.00 (25.4)	1.00 (25.4)	0.44 (11.13)	0.44 (11.13)	2.61 (66.29)	1.38 (34.93)	0.38 (9.65)	17/32 (13.49)
		603-3	0.201 (5.11)	2.00 (50.8)	1.00 (25.4)	1.00 (25.4)	0.44 (11.13)	0.44 (11.13)	2.61 (66.29)	1.38 (34.93)	0.38 (9.65)	17/32 (13.49)
Fractional Tube Fitting to Male NPT	3/8	125	0.172 (4.37)	2.11 (53.59)	1.20 (30.38)	0.91 (23.01)	0.40 (10.16)	0.38 (9.53)	2.55 (64.77)	1.38 (34.93)	0.38 (9.65)	17/32 (13.49)

Lower Packing Valves

400 Series Valves

400 Series lower packing needle valves provide positive shutoff for applications having working pressures up to 5000 psig. Lower packing needle valves feature packing below the stem threads to maintain stem lubrication and to protect stem threads from corrosive or erosive media. With orifice sizes up to 0.562 in. and end connections up to 1 in., 400 Series needle valves offer higher flow than other instrumentation needle valves.



Product Design

- 1 Durable Handle
 - Brass insert
 - Stainless Steel T-bar
 - Stainless Steel Knurled
- 2 Non-wetted Actuation Thread
 - Protects lubricant and valve operation
 - Reduces system contamination
 - Ease of actuation
 - Precise regulation
 - Tight shutoff

STRAIGHT AND ANGLE FLOW PATH
100% FACTORY TESTED

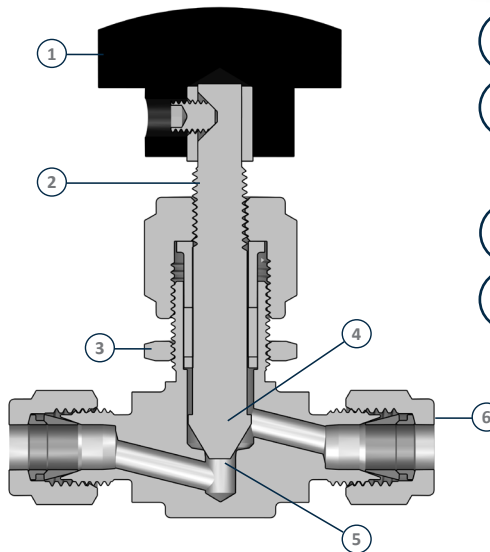

- 3 Panel Mounting
- 4 Stem Tips
 - All metal blunt tip
 - PCTFE soft tip
- 5 Variety of orifice sizes
- 6 Variety of end connections

Pressure - Temperature Chart

	Stainless Steel	
Temp Rating	Metal Stem	-40°F to 450°F
	Kel-F Stem Point	-40°F to 200°F
Pressure Rating @ 100°F	5,000 psig	

Materials of Construction

ID	Component	316 SS	Brass
1	Body*	316 Stainless Steel	Brass
2	Panel Nut	Stainless Steel	Brass
3	Stem**	316 Stainless Steel	316 Stainless Steel
4	Packing Support*	316 Stainless Steel	316 Stainless Steel
5	Packing*	PTFE	PTFE
6	Packing Pusher*	PTFE	PTFE
7	Packing Nut	316 Stainless Steel	316 Stainless Steel
8	Set Screw	316 Stainless Steel	316 Stainless Steel
9	Handle	Phenolic	Phenolic

*Wetted Components

**2 piece stem (Female npt 3/4in & 1in)

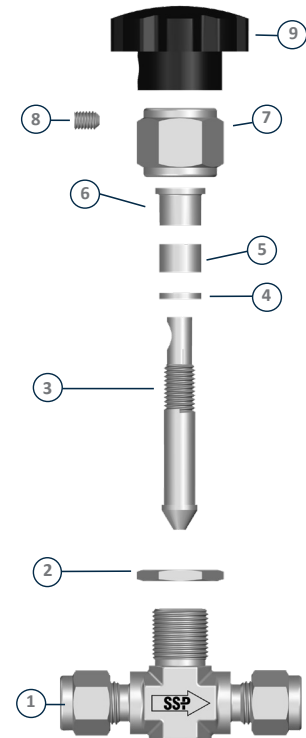

How to Order

400 Series Lower Packing Valves

Ordering Instructions

- 1 Add "A" for angled valve or leave blank for straight. Example **A**
- 2 Add the basic part number. Example **A400**
- 3 Add the material. Example **A400-316**
- 4 Add stem type. Example **A400-316-K**
- 5 Add options from the Chart E. Example: **A400-316-K-U**



A **B** - **C** - **D** **E**

A 400 -316 -K -U

A **ANGLE PATTERN**
Blank Straight
A Angle

B **BASIC PART NUMBER**
See Chart

C **MATERIAL**
-316 316 Stainless Steel
-B Brass

D **STEM TYPE**
Blank Metal Stem Tip (Vee)
K Soft Seat, PCTFE

E **OPTIONS**

Handles

Black Blank (Standard)
SS Tee Bar -TBH

Tube End Connections

Duolok Blank (Standard)
Unilok -U
Griplok -G

400 Series Lower Packing Valves

Part Numbers and Dimensions

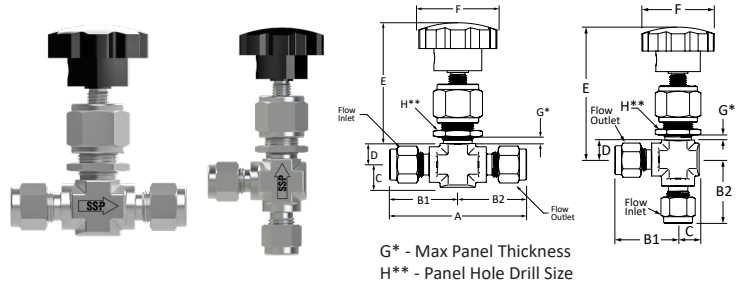

End Connection		Basic Part Number	Dimensions in. (mm)									
Inlet/Outlet	Size		Orifice	A	B1	B2	C	D	E	F	G	H
Fractional Tube Fitting	1/8	400-316	0.172 (4.37)	2.34 (59.44)	1.168 (29.67)	1.168 (29.67)	0.4 (10.16)	0.375 (9.53)	2.5 (63.5)	1.375 (34.93)	0.25 (6.35)	19/32 (15.08)
	1/4	422-316	0.172 (4.37)	2.4 (60.96)	1.2 (30.48)	1.2 (30.48)	0.4 (10.16)	0.375 (9.53)	2.5 (63.5)	1.375 (34.93)	0.25 (6.35)	19/32 (15.08)
	3/8	428-316	0.172 (4.37)	2.4 (60.96)	1.196 (30.38)	1.196 (30.38)	0.4 (10.16)	0.397 (10.08)	2.5 (63.5)	1.375 (34.93)	0.25 (6.35)	19/32 (15.08)
	1/2	436-316	0.172 (4.37)	2.62 (66.55)	1.308 (33.22)	1.308 (33.22)	0.505 (12.83)	0.505 (12.83)	2.5 (63.5)	1.375 (34.93)	0.25 (6.35)	19/32 (15.08)
Female NPT	1/8	408-316	0.172 (4.37)	1.82 (46.23)	0.906 (23.01)	0.906 (23.01)	0.4 (10.16)	0.375 (9.53)	2.5 (63.5)	1.375 (34.93)	0.25 (6.35)	19/32 (15.08)
	1/4	418-316	0.172 (4.37)	2.0 (50.8)	1.0 (25.4)	1 (25.4)	0.438 (11.13)	0.442 (11.23)	2.5 (63.5)	1.375 (34.93)	0.25 (6.35)	19/32 (15.08)
	3/8	438-316	0.25 (6.35)	2.5 (63.5)	1.25 (31.75)	1.25 (31.75)	0.74 (18.8)	0.75 (19.05)	2.87 (72.9)	1.75 (44.45)	0.25 (6.35)	19/32 (15.08)
	1/2	440-316**	0.312 (7.92)	2.62 (66.55)	1.312 (33.32)	1.312 (33.32)	0.75 (19.05)	0.75 (19.05)	2.79 (70.87)	3.0 (76.2)	0.25 (6.35)	25/32 (19.84)
	3/4	442-316**	0.438 (11.13)	2.9 (73.66)	1.45 (36.83)	1.45 (36.83)	0.69 (17.53)	0.75 (19.05)	3.5 (88.9)	3.5 (88.9)	N/A	N/A
	1	444-316**	0.562 (14.27)	3.62 (91.95)	1.81 (45.97)	1.81 (45.97)	0.89 (22.61)	1.03 (26.16)	4.0 (101.6)	0.35 (101.6)	N/A	N/A
Male NPT	1/8	406-316	0.172 (4.37)	1.82 (46.23)	0.906 (23.01)	0.906 (23.01)	0.4 (10.16)	0.375 (9.53)	2.5 (63.5)	1.375 (34.93)	0.25 (6.35)	19/32 (15.08)
	1/4	410-316	0.172 (4.37)	1.82 (46.23)	0.906 (23.01)	0.906 (23.01)	0.4 (10.16)	0.375 (9.53)	2.5 (63.5)	1.375 (34.93)	0.25 (6.35)	19/32 (15.08)
	3/8	430-316	0.172 (4.37)	2.26 (57.4)	1.125 (28.58)	1.125 (28.58)	0.438 (11.13)	0.442 (11.23)	2.5 (63.5)	1.375 (34.93)	0.25 (6.35)	19/32 (15.08)
Male NPT to Fractional Tube Fitting	1/4	414-316	0.172 (4.37)	2.11 (53.59)	0.906 (23.01)	1.2 (30.48)	0.4 (10.16)	0.375 (9.53)	2.5 (63.5)	1.375 (34.93)	0.25 (6.35)	19/32 (15.08)
Male NPT to Female NPT	1/4	412-316	0.172 (4.37)	2.0 (50.8)	1.0 (25.4)	1 (25.4)	0.438 (11.13)	0.442 (11.23)	2.5 (63.5)	1.375 (34.93)	0.25 (6.35)	19/32 (15.08)

*2 piece stem (Female npt 3/4in & 1in)
 ** SS Bar T-Handle

Toggle Valves

200 Series Toggle Valves

Toggle Valves are designed for quick actuation and positive on-off control of media in low pressure and temperature applications encountered in instrumentation and process systems.



Product Design

- 1 Spring-Loaded Actuation
 - Quick opening and closing
 - Visual flow indication
 - Positive shutoff to 200 PSIG
 - High-Cycle Life

- 2 Panel Mountable

- 3 Durable Handle
 - Solid Brass
 - Chrome plated option

- 4 O-Ring Stem Seal

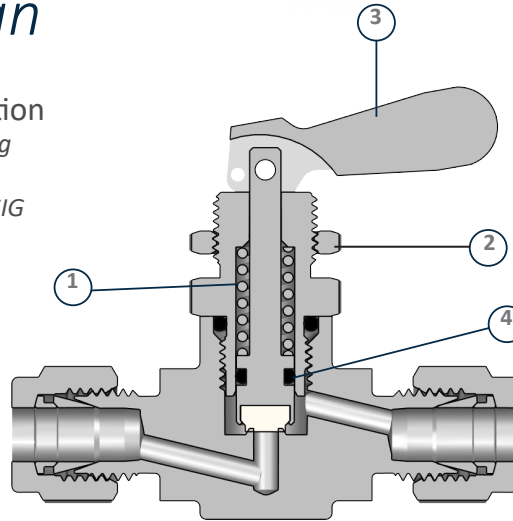

Straight and Angle Flow Path

Variety of End Connections

- Fractional Duolok®, Unilok® and Griplok® tube ends
- Metric Duolok® tube ends
- TruFit® NPT and ISO/BSPT pipe ends

100% Factory tested

Pressure - Temperature Chart

	Stainless Steel	Brass
Temp Rating	-20°F to 200°F	-20°F to 200°F
Pressure Rating @ 100°F	200 psig	200 psig

Materials of Construction

ID	Component	316 SS	Brass
1	Body*	316 SS	Brass
2	Stem O-Ring Seal*	FKM	FKM
3	Bonnet O-Ring Seal*	FKM	FKM
4	Spring	316 SS	316 SS
5	Bonnet*	316 SS	Brass
6	Panel Nut	316 SS	Brass
7	Stem*	316 SS with PTFE Tip	316 SS with PTFE Tip
8	Handle Pin	Stainless Steel	Stainless Steel
9	Handle	Brass Chrome Plated	Brass

*Wetted Components

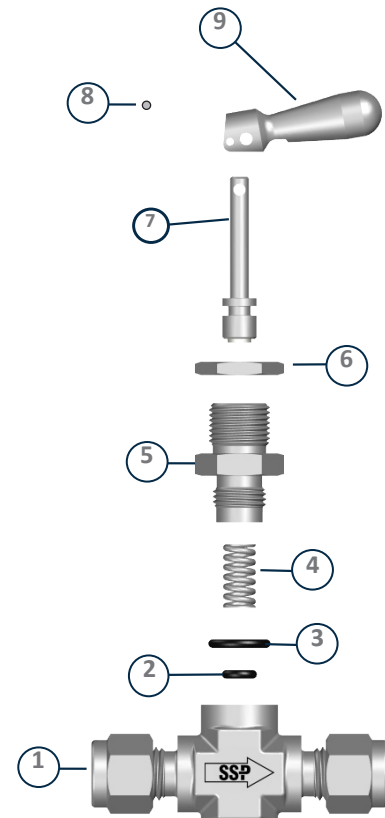

How to Order

200 Series Toggle Valves

Ordering Instructions

- 1 For angle valves, Add "A" to the beginning of the part number. Example: A
- 2 Select the basic part number from the Part Numbers and Dimensions table based on the end connections for the valve. Example: A208
- 3 Add the body material designator to part number. Example: A208-316
- 4 Add options from the Chart D. Example: A208-316-U



A ANGLE PATTERN

Blank Straight
A Angle

B BASIC PART NUMBER

See Chart Below

C MATERIAL

-B Brass
-316 Stainless Steel

D OPTIONS

Seal Material		Tube End Connections	
Nitrile	-BN	Duolok	Blank (Standard)
		Unilok	-U
		Griplok	-G

Part Numbers and Dimensions

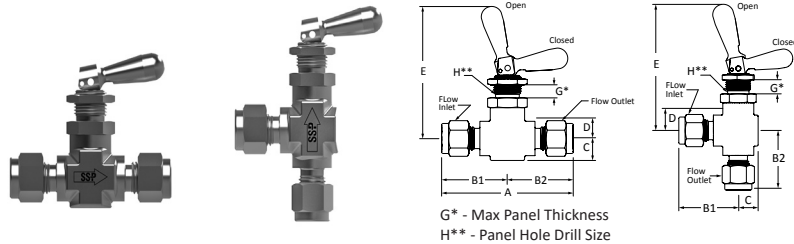

G* - Max Panel Thickness
H* - Panel Hole Drill Size

End Connection		Basic Ordering Number	Dimensions in. (mm)									
Inlet/Outlet	Size		Orifice	A	B1	B2	C	D	E	F	G	H
Fractional Tube Fitting ¹	1/8	206	0.094 (2.4)	2.34 (59.4)	1.17 (29.7)	1.17 (29.7)	0.40 (10.2)	0.38 (9.6)	2.34 (59.6)	1.12 (28.5)	0.25 (6.4)	17/32 (13.5)
	1/4	208	0.125 (3.2)	2.40 (60.9)	1.20 (30.4)	1.20 (30.4)	0.40 (10.2)	0.38 (9.6)	2.34 (59.6)	1.12 (28.5)	0.25 (6.4)	17/32 (13.5)
	3/8	212	0.125 (3.2)	2.40 (61.0)	1.20 (30.4)	1.20 (30.4)	0.40 (10.2)	0.38 (9.6)	2.34 (59.6)	1.12 (28.5)	0.25 (6.4)	17/32 (13.5)
Female NPT	1/8	202	0.125 (3.2)	3.62 (92.0)	1.81 (46.0)	1.81 (46.0)	0.40 (10.2)	0.38 (9.6)	2.34 (59.6)	1.12 (28.5)	0.25 (6.4)	17/32 (13.5)
	1/4	215	0.125 (3.2)	2.00 (50.8)	1.00 (25.4)	1.00 (25.4)	0.40 (10.2)	0.38 (9.6)	2.34 (59.6)	1.12 (28.5)	0.25 (6.4)	17/32 (13.5)
Male NPT	1/8	200	0.125 (3.2)	1.82 (46.2)	0.91 (23.0)	0.91 (23.0)	0.40 (10.2)	0.38 (9.6)	2.34 (59.6)	1.12 (28.5)	0.25 (6.4)	17/32 (13.5)
	1/4	204	0.125 (3.2)	1.82 (46.2)	0.91 (23.0)	0.91 (23.0)	0.40 (10.2)	0.38 (9.6)	2.34 (59.6)	1.12 (28.5)	0.25 (6.4)	17/32 (13.5)
Male NPT to Fractional Tube Fitting	1/4	209	0.125 (3.2)	2.11 (53.6)	0.91 (23.0)	1.2 (30.4)	0.40 (10.2)	0.38 (9.6)	2.34 (59.6)	1.12 (28.5)	0.25 (6.4)	17/32 (13.5)

For more information on fittings for process and instrumentation systems manufactured by SSP, please request the catalogs pictured below.

Duolok[®]
Tube Fittings



Unilok[®]
Tube Fittings



Griplok[®]
Tube Fittings

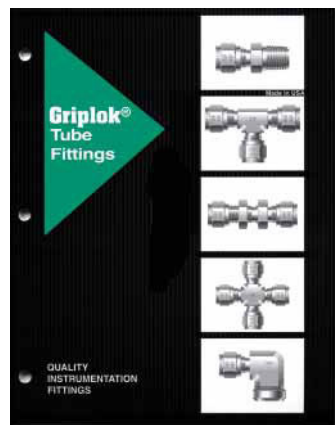

TruFit[®]
*Pipe, Weld
and Adapter Fittings*



SSP Valves

LIFETIME LIMITED WARRANTY

SSP valves are guaranteed to be free from defects in materials and workmanship. To initiate a warranty claim, suspected defective product must be returned with the nature of potential defect documented for factory evaluation. Any product with a determined defect in material or workmanship will be replaced with equivalent product at no charge.

This warranty comprises the sole and entire warranty pertaining to items provided hereunder. There is no other warranty, guarantee, express or implied representation of any kind whatsoever. All other warranties including, but not limited to, merchantability and fitness for purpose, whether express, implied, or arising by operation of law, course of dealing, or trade usage are hereby disclaimed. There are no warranties that extend beyond the description on the face hereof; and this warranty does not apply in cases of abuse, mishandling, or normal use depreciation. In no event, whether alleged to arise from breach of contract, express or implied warranty, by operation of law, negligence or otherwise, will there be any liability for any incidental, consequential, lost property, or other special damages of any kind whatsoever. The exclusive, only remedy under this warranty is the replacement of determined defective parts as set forth above.

Safety

To help ensure the safe and reliable performance of valve products, complete system design must be considered prior to the installation of the valves and end connections.

Determining the design compatibility of materials, media, flows, temperatures and pressures, as well as implementing proper installation, operation and maintenance of the system are the responsibilities of the systems' owners, designers and users.

Safety Reminders

All SSP products are designed and manufactured with safety in mind. The following is a limited list of general safety tips as reminders of good safety practices:

- Do not install, tighten or loosen a valve or filter while the system is under pressure.
- Do not loosen a valve, filter, nut or end connection to relieve or bleed system pressure.
- Always use a back-up wrench to hold the valve or filter body steady when tightening or loosening end connections.
- There is no need to disassemble a new valve or filter prior to use.
- Use proper thread lubricants and sealants on tapered pipe threads.
- If Fractional Tube Fitting end connections are used with very soft pliable plastic tubing, a tube insert is required for proper installation.
- Valve Tube Fitting end connection and tubing material should be similar (stainless steel fittings on stainless steel tubing, brass fittings on copper tubing, etc.) with the tubing material being fully annealed.

More SSP Products



Tube Fittings

Duolok® and Griplok® (two-ferrule) and Unilok® (single-ferrule) tube fittings ensure leak-tight installation when intermixed with Swagelok®, Hoke® Gyrolok®, and Parker® CPI™ fittings, provided they are used in accordance with SSP Fittings' published installation and service recommendations.



Valves

The SSP valve offering includes ball, check, metering, needle, toggle, plug, bleed, and purge valves for pressures up to 10,000 psig.



Quick Connects

SSP offers single-end shutoff, double-end shut off, and full-flow quick connects for instrumentation and process applications.



Pipe Fittings

TruFit and TruFit 10K pipe fittings are available in a wide range of weld, threaded and flared connections.



Filters

SSP in-line and tee-type filters trap particles to clean sample fluids and protect sensitive process and analytical instrumentation components and equipment.



Tools & Accessories

SSP TurnPro professional hand tools, power tools and installation training make quality tube system installation faster and easier.



SSP

Founded 1926

Privately owned, third generation business

Modern single-site vertically integrated manufacturing facility

DFARS-compliant raw material

ISO 9001 quality management system

Limited Lifetime Warranty



8250 Boyle Parkway • Twinsburg, OH 44087
330-425-4250 • www.mySSP.com